

Cable Layout:

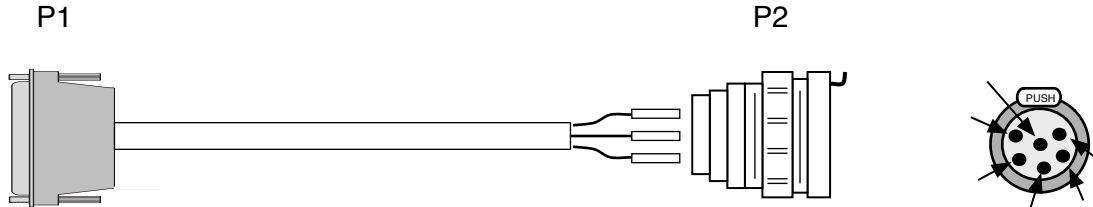

Requires 1.25-inch dia. minimum mounting hole.
See Switchcraft catalog for mounting details.

CA-D15M-X6FP-L-A_02

Length in Feet

Wiring Information:

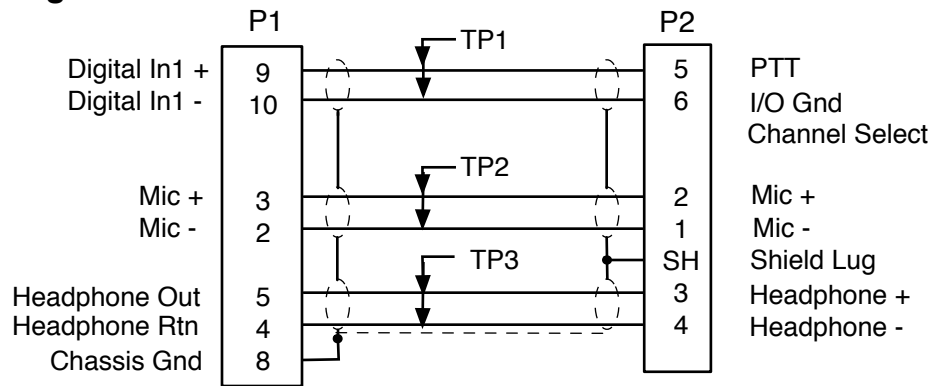

Notes:

1. Use high quality supplier such as AMP or equivalent.
2. Use quality low capacitance, high flex audio cable. Canare MR202-4AT audio cable is to be used.
3. Tie ALL shields to Pin 8 at the D15 end. Tie ALL shields to the shield lug at the 6 pin XLR end. Pairs must be connected as shown
4. Cable length "L" defined by length field of part number ordered
4. P2: Switchcraft B6F

Rev	Date	Originator	Description
01	2-21-06	NAK	Original release
02	4-15-09	CJA	Added information table

		ADVANCED SIMULATION TECHNOLOGY inc. 500A Huntmar Park Drive, Herndon, VA 20170 www.asti-usa.com
Cage Code	OVFW3	
Title	Audio Cable IRIS to 6-pin XLR Panel Mount	
Dwg #	CA-D15M-X6FP-L-A_02	
Sheet	1 of 1	

Industry connector Sub Group	ASTi Part Number Sub Group	Source Device	ASTi Part Number	Current Revision Number	Description & Case Use	Special Notes
DB15	D15*	ACU, ACU2	CA-D15M-X6FP-L-A	02		