



**Advanced Simulation Technology inc.**  
441-A Carlisle Drive  
Herndon, Virginia 20170 U.S.A.  
Tel. (703)471-2104 • Fax. (703)471-2108  
[www.asti-usa.com](http://www.asti-usa.com)

**ASTi**  
**Remote Interface Unit**  
**Version 4.1**  
**Technical Guide**

**Document: ASSY-01-RIU04-MN-2**

# Table of Contents

<b>Remote Interface Unit (RIU) General Information</b> .....	<b>1</b>
<i>Power Supply</i> .....	<b>2</b>
<i>Connector Information</i> .....	<b>2</b>
<b>Audio Output Stage</b> .....	<b>3</b>
<b>Audio Input Stage</b> .....	<b>4</b>
<b>Digital Input</b> .....	<b>5</b>
<i>Digital Input examples:</i> .....	<b>5</b>
<b>Digital Output</b> .....	<b>6</b>
<i>Providing surge protection for the DO circuitry</i> .....	<b>6</b>
<b>RIU EEPROM</b> .....	<b>7</b>
<b>Creating the TDM Ring</b> .....	<b>8</b>
<i>RIU Indicator Lights</i> .....	<b>8</b>
<b>Connecting equipment to the RIU</b> .....	<b>9</b>
<i>Typical application drawing:</i> .....	<b>9</b>
<i>Typical Operator Station using Headset and PTT:</i> .....	<b>10</b>
<b>Using RIU Serial Ports</b> .....	<b>11</b>
<b>Identifying RIU versions</b> .....	<b>12</b>
<i>Current Version:</i> .....	<b>12</b>
<i>Previous Versions:</i> .....	<b>12</b>
<b>Rackmounting RIUs</b> .....	<b>13</b>
<i>Ordering Information</i> .....	<b>13</b>
<b>Additional Information</b> .....	<b>14</b>
<b>RMA Instructions</b> .....	<b>14</b>
<b>DISCLAIMER</b> .....	<b>14</b>

## Remote Interface Unit (RIU) General Information

- A packaged RIU weighs 1.5 lbs. The power supply included with the RIU weighs 0.5 lbs.
- 19", 1U high rackmount kits are available. Each kit will hold 3 RIUs and/or Audio Interface Units (AIUs).

### RIU Front Panel Face

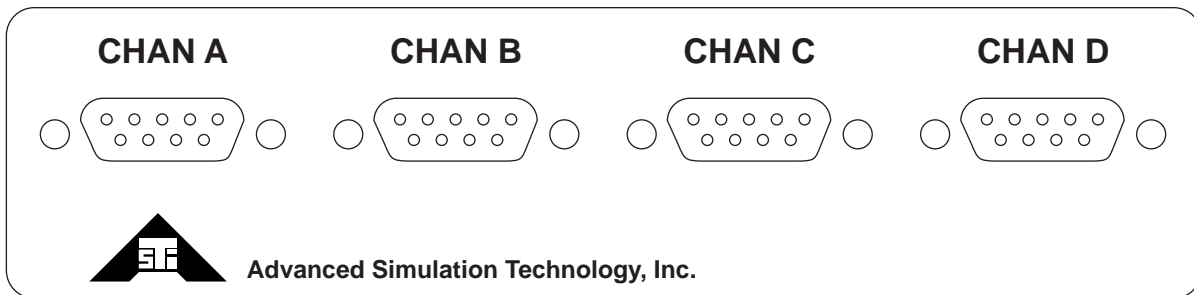

### RIU Rear Panel Face

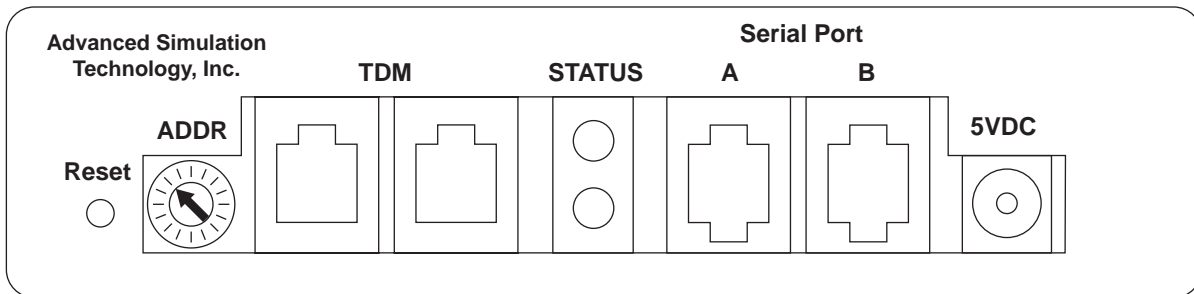

### RIU Dimensions

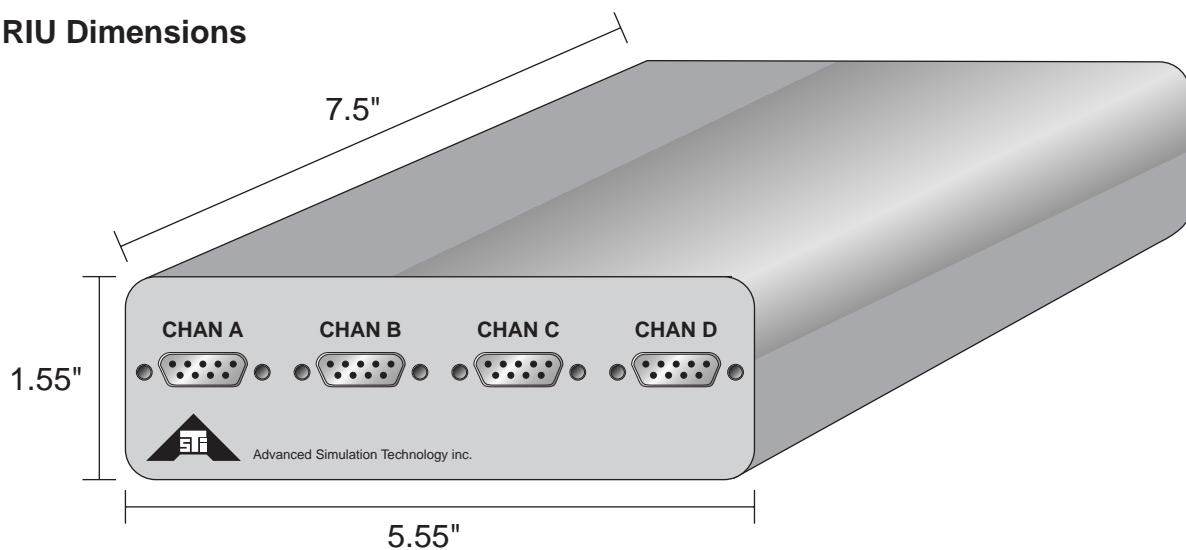

## Power Supply

- Each RIU is supplied with an external +5 VDC regulated power supply. These power supplies are rated for 50/60Hz, 100-240Vac, and will supply a maximum of 2.5A.
- The RIU includes an over-current protection device (1.1A trip point) that automatically resets itself.

## Connector Information

- Power Supply: 2.1mm socket, center positive
- Serial connections A & B: RJ-12 jacks
 

1 = TX+	4 = RX-
2 = TX-	5 = +5 VDC
3 = RX+	6 = Ground
- TDM Link In/Out: RJ-45 jacks
 

1 = RX+	5 = SYN+
2 = RX-	6 = TX-
3 = TX+	7 = SCK+
4 = SYN-	8 = SCK-
- Channels A, B, C & D: 9-pin, female, subminiature 'D' connector
 

1 = Digital Out +	6 = Digital Out-
2 = Audio Out, Hi	7 = Audio Out, Lo
3 = Digital In+	8 = Digital In- (I/O GND)
4 = Audio In, Hi	9 = Audio In, Lo
5 = Chassis Ground	

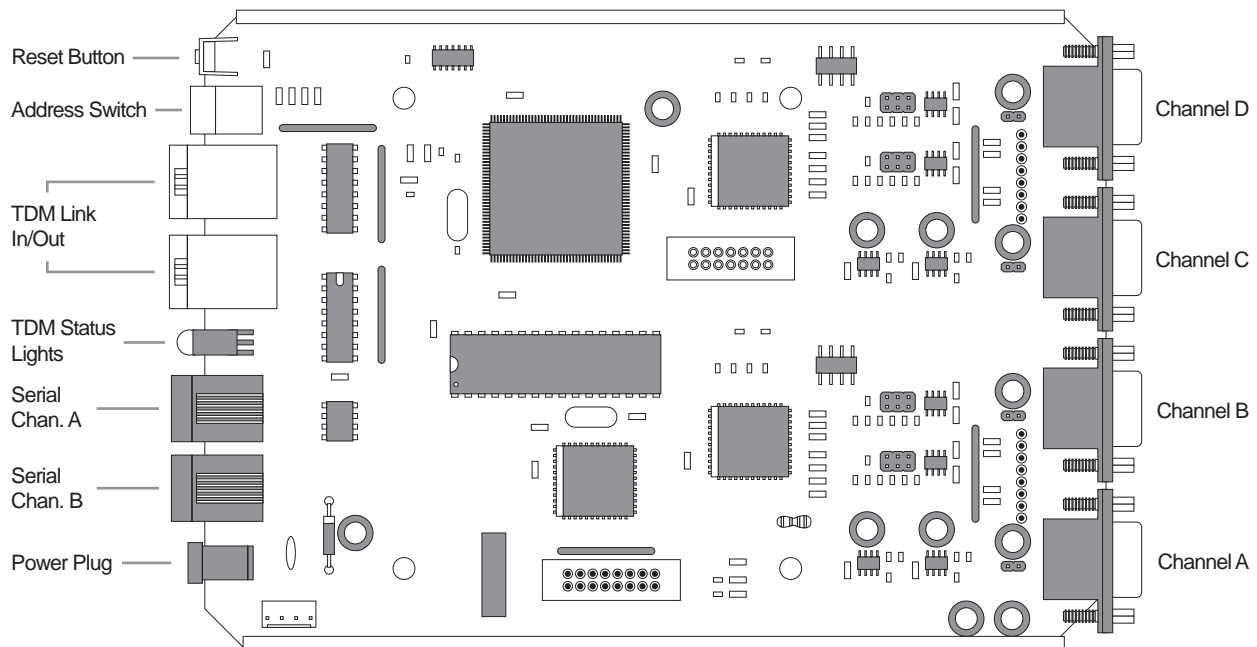

## Audio Output Stage

Note: Only one channel of the audio output stage is shown, the remaining 3 channels are identical.

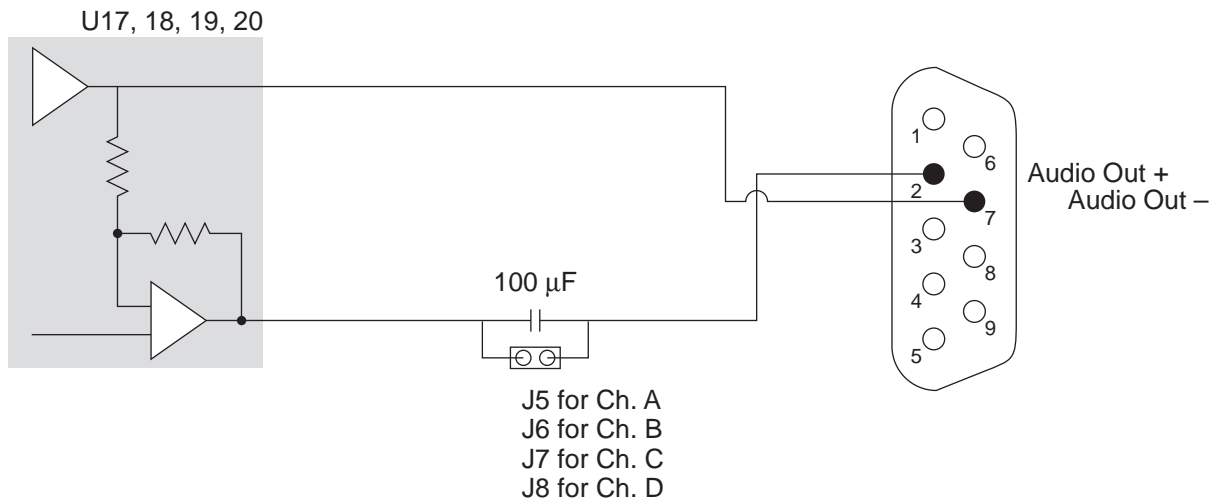

### Bridge Connected Load

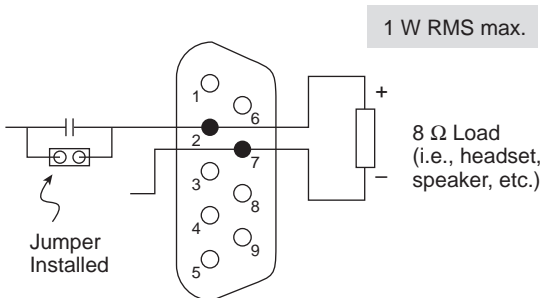

### Single-Ended Load

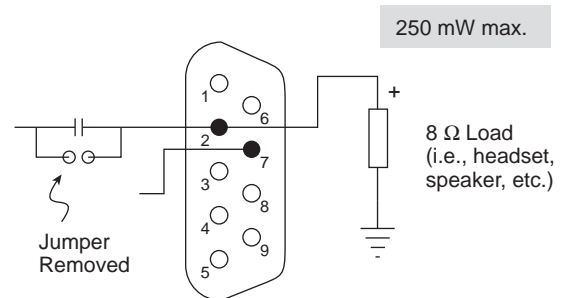

The RIU is capable of driving a wide range of audio devices. These devices include, but are not limited to: headsets, speakers, VCRs, tape drives, and ASTi's Audio Interface Unit (AIU). The output impedance range for these devices is nominally 8-300  $\Omega$ .

Each channel is capable of supplying 1 Watt RMS into a bridge connected 8  $\Omega$  load. If a single ended 8  $\Omega$  load is connected to the output, the RIU is capable of supplying 250 mWatts RMS.

The output impedance of each channel (with J5, J6, J7, and J8 installed) is typically 0.1  $\Omega$  into an 8  $\Omega$  load.

Each RIU channel provides a balanced output with a maximum signal level of +/- 2.25 V<sub>peak</sub>. When used to drive a single ended load, the output maximum signal level is +2.25 V<sub>peak</sub>.

When driving bridge connected (differential) loads, install jumpers J5, J6, J7 or J8, whichever is applicable for the channel.

When driving a single ended load, remove J5, J6, J7 or J8, whichever is applicable for the channel, and take the output signal from pin 2 of the DB-9 connector. Pin 7 of the DB-9 can be left floating, there is no need to connect a dummy load to the unused output, or to tie it to ground.

See User Servicable Components diagram, page 7 for jumper locations.

## Audio Input Stage

Note: Only one channel of audio input stage is shown, the remaining 3 channels are identical.

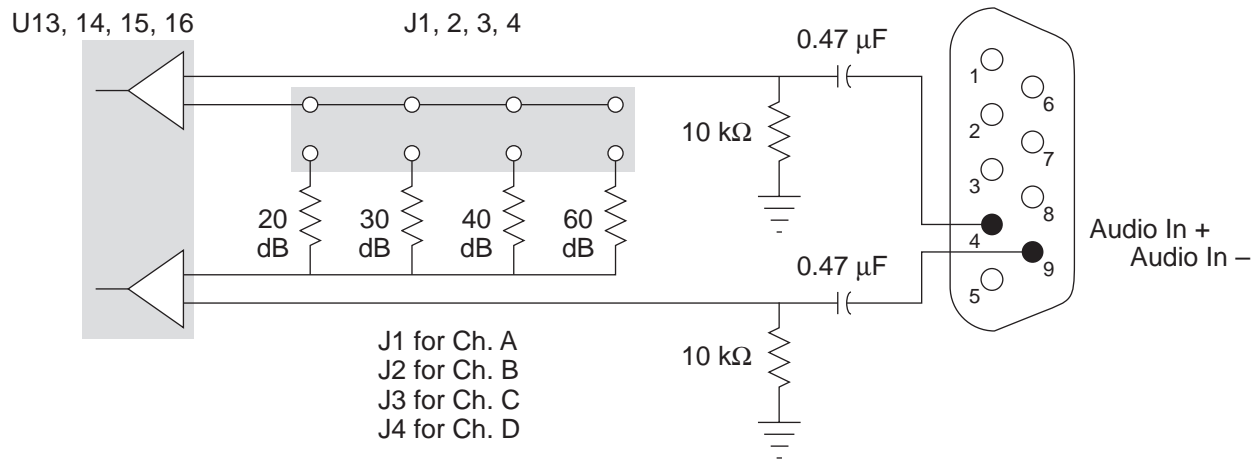

### Setting the gains:

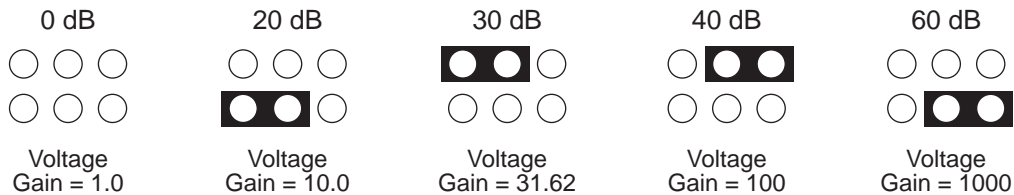

The RIU is capable of receiving audio input(s) from a wide variety of devices. These audio sources include, but are not limited to: microphones (freestanding and headset mics), PC sound cards, VCRs, tape drives, and ASTi's Audio Interface Unit (AIU). The nominal input impedance of each stage is 5 k $\Omega$ .

With a 0 dB gain setting the maximum input signal level that can be applied without distortion by the RIU is +/- 2.5 V<sub>peak</sub>. Theoretically an input signal as small as +/- 5 mV<sub>peak</sub> could be applied to the audio input. However it might not be possible to actually use a +/- 5 mV<sub>peak</sub> signal input to the RIU due to on-board circuit noise, ambient noise (both audio and electronic), interface cabling construction and microphone characteristics. (See Note 1 below.)

The input gains for each channel are set using jumper blocks J1(ChA), J2(ChB), J3(ChC) and J4(ChD). Gain values are; no jumper = 0 dB (line level input), 20, 30, 40 or 60 dB.

See User Servicable Components diagram, page 7 for jumper locations.

*Note 1:* If in doubt as to your headset's compatibility with the RIU ASTi provides a headset evaluation service. Check our website for details.

## Digital Input

Note: Only one channel of the digital input circuitry is shown, the remaining 3 channels are identical.

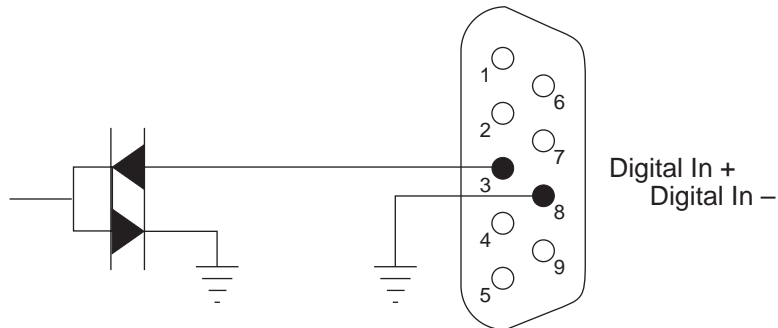

The RIU provides contact-sensing digital inputs; no power is required. Connecting the DI+ and DI- lines together triggers the digital input.

The digital inputs on the RIU are useful for providing a direct interface with Press-To Talk (PTT) switches. This means that the PTT input is fed directly into the model, thereby eliminating control latency associated with Host I/O systems.

### Digital Input examples:

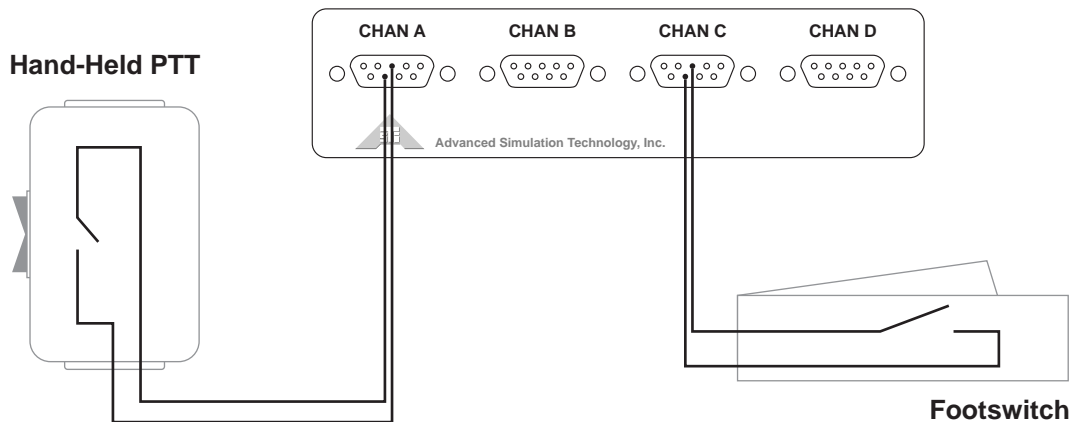

ASTi has several Press-to-Talk devices available. Please consult our website for details.

## Digital Output

Note: Only one channel of the digital output circuitry is shown, the remaining 3 channels are identical.

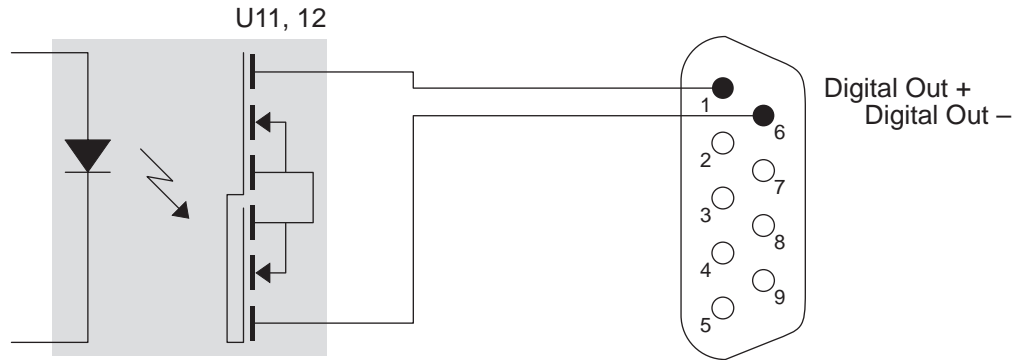

The digital output circuitry consists of an opto-isolate, solid state relay for switching power to external loads.

Each DO circuit has a continuous current rating of 120 mA maximum, and a maximum power dissipation rating of 180 mW.

While providing 10 mA of load current the MOSFET on-state resistance is typically  $21\Omega$ .

The relay's maximum response frequency is 500 Hz.

### Providing surge protection for the DO circuitry.

When driving an inductive load, such as a relay coil, always use a C/R snubber or clamping diode in parallel with the load to suppress large spikes.

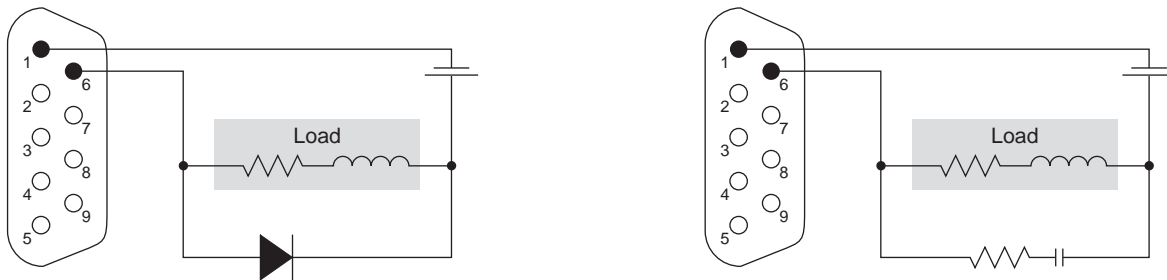

## RIU EEPROM

The EEPROM chip, U5, is a 32-pin DIP, socketed IC located roughly in the middle of the RIU. It is this chip that gives the RIU its characteristics.

See User Servicable Components diagram below.

There is a printed label on the chip showing the firmware version. RIUs with firmware versions 1.x.x are for use with Model Builder 3.x. RIUs with firmware versions 2.x.x are for use with Model Builder 4.x.

The firmware versions are not backward compatible, but the EEPROMs can be replaced permitting older RIUs to be used with newer versions of Model Builder. (See restrictions in the next section)

Contact ASTi for instructions and precautions for replacing firmware.

## User Servicable Components

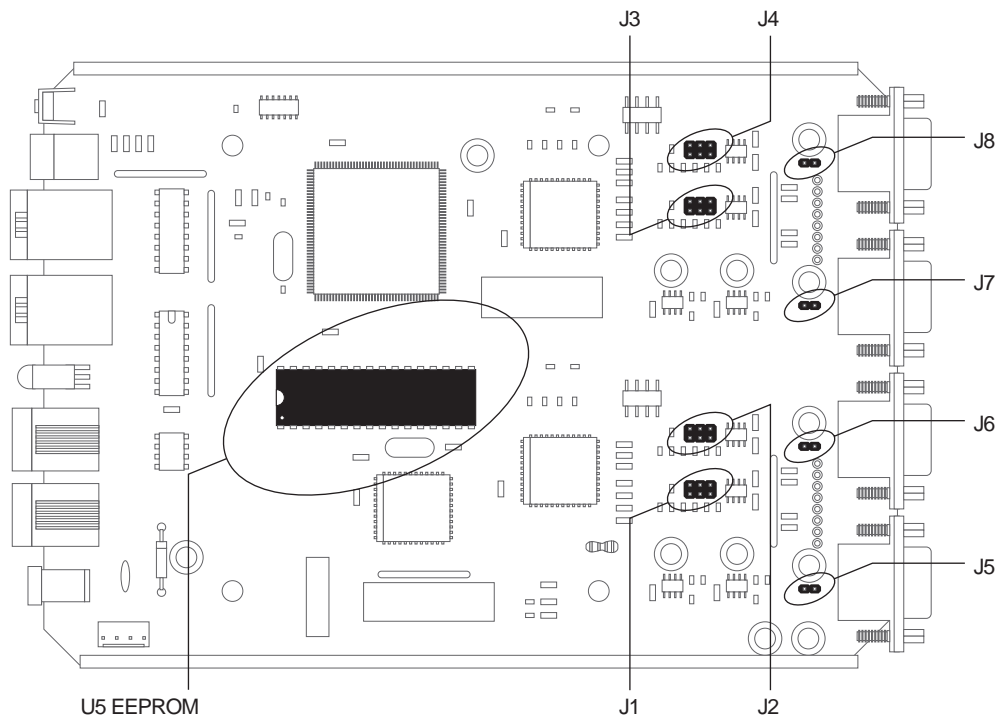

*Warning: Take ESD precautions when handling the RIU board, EEPROM, or jumpers. When changing jumpers, first touch chassis ground, and then reposition the jumper.*

## Creating the TDM Ring

RIUs are connected to each other and to the DACS using standard 4-pair, category 5 network cables.

The complete TDM ring length is limited to 300 feet.

Each RIU on the ring must have a unique address (1 through F, *0 is not valid*). The blue rotary switch next to the reset button is used to set the address. The RIUs on the ring do not need to be sequentially addressed.

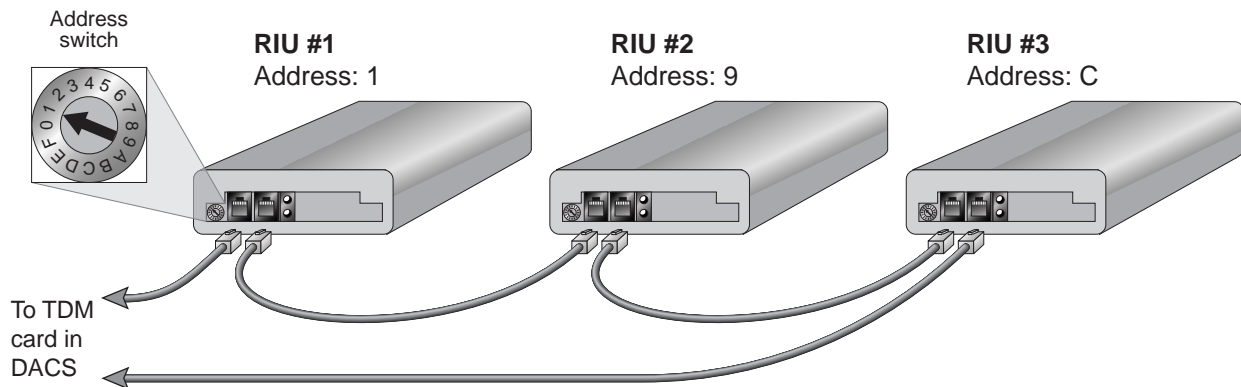

### RIU Indicator Lights

- Green LED = Synchronization Light
- Red LED = Error Light

The red error light will illuminate if no “sync” signal is being received by the RIU (e.g., the RIU is powered on, but the system is not running).

The green “sync” light indicates the synchronization status of the RIU. The RIU must synchronize with a clock signal on the TDM ring, and cannot pass any sound or data until it has done so. The green “sync” light will blink at a 5 Hz rate if the clock signal is present, but the RIU has not synchronized. It will blink at a 1 Hz rate once the RIU has synchronized.

If both the red and green LEDs are illuminated simultaneously, reset the RIU until this condition clears.

## Connecting equipment to the RIU

An RIU contains 4 audio and digital in/out channels but typically two independent operators are serviced per RIU. The two remaining channels may be used as audio outputs for observer speakers or for input to recording devices such as VCRs.

Since each channel of the RIU has independently configurable gains, different types of headsets may be connected to the various channels of the RIU.

For headsets requiring Phantom Power an Audio Interface Unit (AIU) is also required. In short, the AIU provides signal conditioning, impedance matching and Phantom Power. Please refer to ASTi's website for more information on this product and its associated cables.

### Typical application drawing:

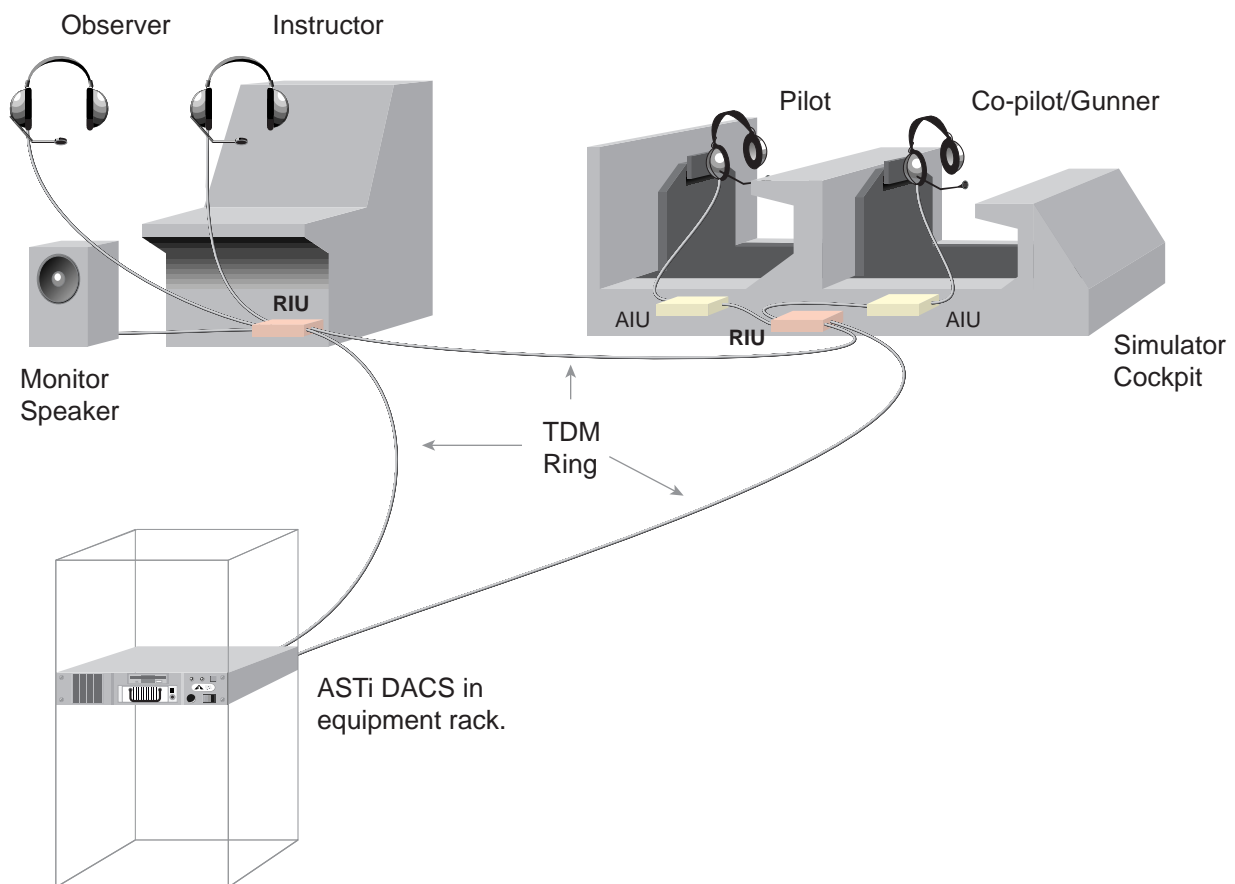

In the picture above, the instructor and observer are using commercial headsets while the students are using military headsets that require Phantom Power. If using low-impedance military headsets that do not require Phantom Power, the headsets could be wired directly to the RIU.

## Typical Operator Station using Headset and PTT:

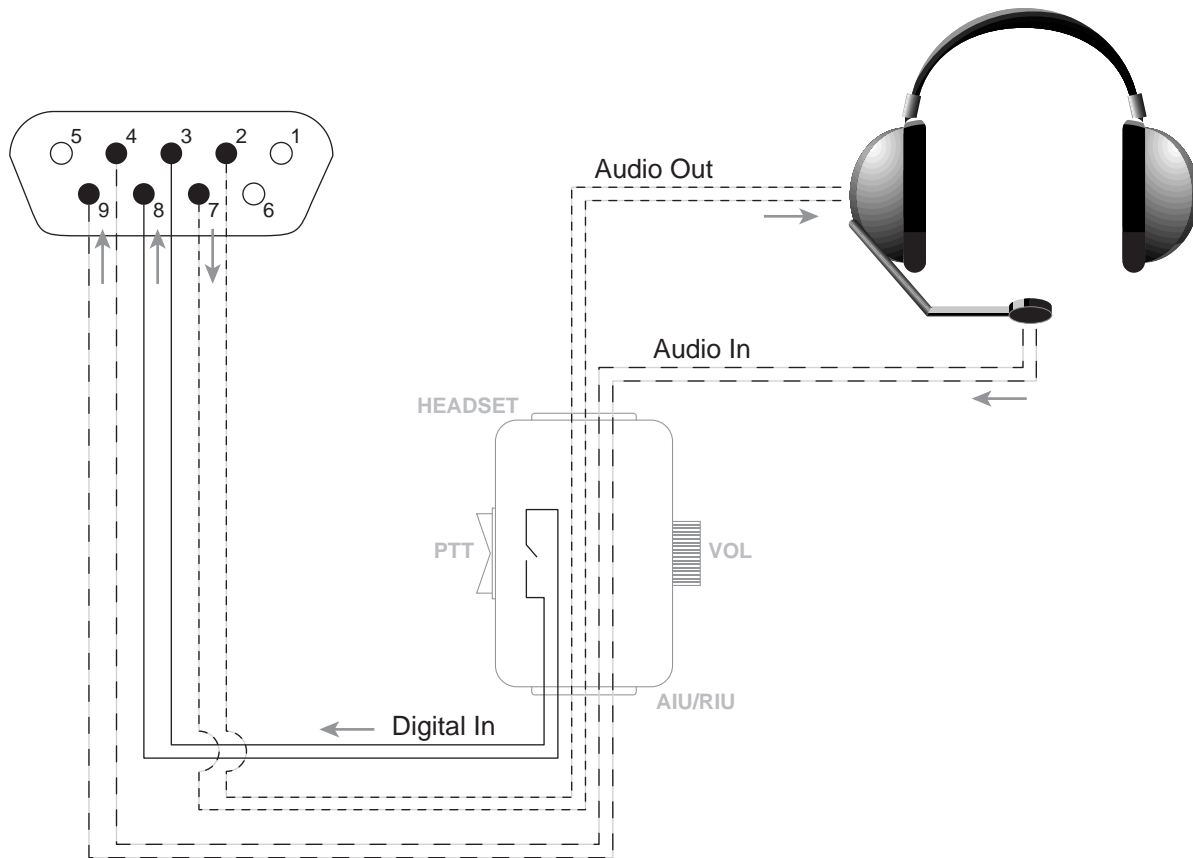

In the diagram above, the ASTi PTT box with volume control is shown only for illustrative purposes. See our website for details.

Use individually shielded, twisted-pair wiring when building audio interface cables. Shields should be tied at a single point to a good earth ground.

## Using RIU Serial Ports

The serial ports permit connection of user interface devices to the RIU. These devices include: high-fidelity simulated panels, I/O modules, and Hand-Held Terminals (HHTs). The data from these devices can be fed directly into the model or it can be passed via ethernet to a Host Computer or another DACS.

Dynamic Link Libraries (dlls) resident on the DACS control and manipulate the serial data. Multiple dlls can run simultaneously, allowing different types of panels to be supported by the same platform.

Many of ASTi's panels support multi-drop usage, permitting several panels of the same type to be connected to the same serial port.

### Single Panel Configuration

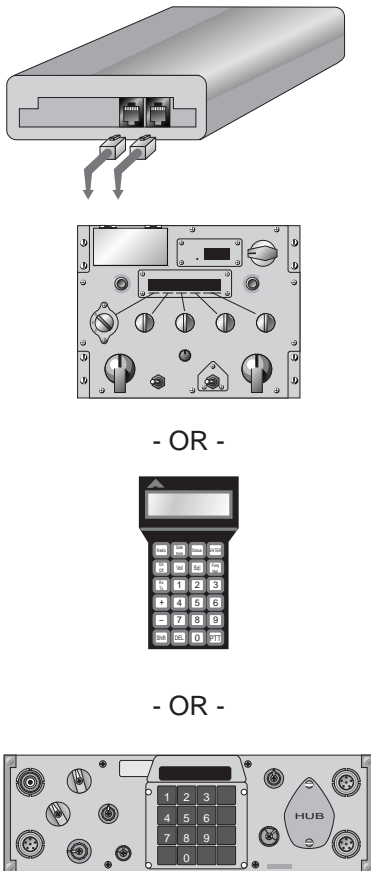

### Multi-dropped Panels

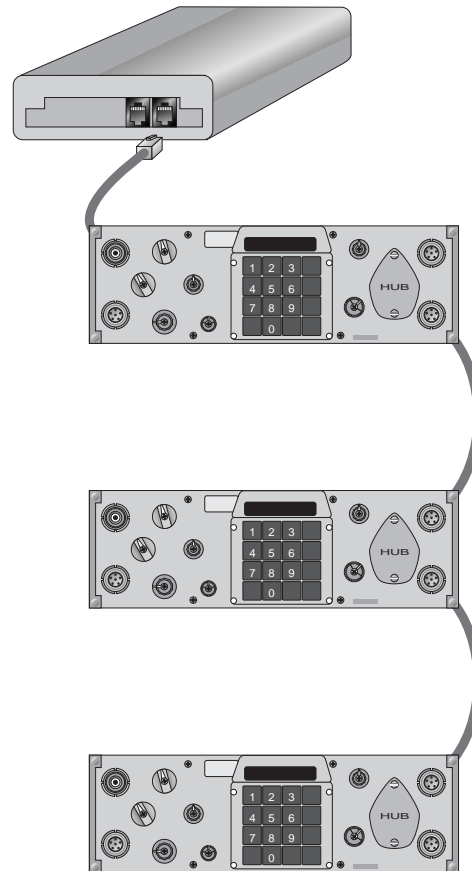

Visit ASTi's website for a comprehensive list of panels supported.

The serial ports are not active when using RIU firmware versions 1.x.x and Model Builder 3.x.

## Identifying RIU versions

There are three versions of the RIU PCB:

- The earliest is the RIU version 3.0. It uses a +12 VDC external power supply, firmware version 1.x.x and works under the 3.x series of Model Builder. This version was not widely distributed and is now obsolete.
- Next in development was the RIU version 3.1b. It uses a +5 VDC external power supply. By installing the appropriate firmware this RIU can be used with either the 3.x or 4.x versions of Model Builder.
- RIU version 4.1 is the most recent. It uses a +5 VDC external power supply and by installing the appropriate firmware version it can be used with either the 3.x or 4.x series of Model Builder. If you plan to use the version 4.1 RIU with the 3.x series of Model Builder, please contact ASTi before doing so.

The different RIU PCBs can be identified in two ways. First, there is a printed label on the bottom of the RIU chassis with a version number on it. Secondly, the hardware version is silkscreened on the RIU board.

### Current Version:

Part Number: RIU-V<sub>xx</sub>-z<sub>z</sub>

In the part number, xx is a number combination denoting the hardware version. For example, “41” denotes RIU board version 4.1

In the part number, zz is used to identify firmware version or special configurations of the board. For example, “AA” indicates Firmware version 2.3.1

Part Number Example: The first production boards of this series will have the part number RIU-V41-AA.

When ordering spares, be sure to specify the complete part number.

### Previous Versions:

Part Number: RIU-04-X-Y

In the part number, X is a letter denoting board versions, firmware version and board modifications (applicable to 3.1b version hardware).

X values:     A = RIU version 3.0 (modified)  
               B = RIU version 3.0  
               C = RIU version 3.1b, firmware 1.x.x for use with MB 3.x  
               D, E, F, G, H = RIU version 3.1b, firmware 2.x.x for use with MB 4.x

Y values:     The Y values are used to identify modified boards within a given series. Frequently, the boards are modified by changing the input and output gain resistors to handle the direct connection of headsets.

There was a two-channel version of the RIU 3.1b. The part number for this was RIU-02-X-Y. The two-channel version is now obsolete.

## Rackmounting RIUs

RIUs may be rackmounted in a 1U high, 19" wide bracket. The bracket will accept any combination of up to 3 RIUs (or AIUs). The brackets can be supplied unassembled, or ASTi can mount the components for a small fee.

**NOTE:** When the RIU is rackmounted, the front bezel of the RIU case is not used. Keep the bezel in the event that the RIU is removed from the bracket and used as a stand-alone unit. Without the bezel, the endplate of the RIU will not fit on the case correctly.

### Ordering Information

For the unassembled bracket only, use ASTi Part Number: RMK-RA-3U.

For the bracket with pre-mounted RIUs or AIUs (up to 3, any combination), use ASTi Part Number: MRK-RA-3A.

#### Rackmount Bracket

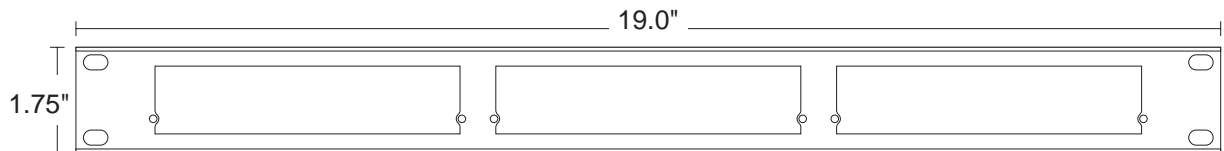

See Application Note #42, "RIU/AIU Rackmount Bracket Specifications", for complete measurements/specs.

#### Installing RIU/AIU into Rackmount Bracket

1. Remove and retain screws near bottom of faceplate.
2. Remove faceplate with white printing.
3. Remove plastic bezel surrounding faceplate. Retain this plastic piece for re-installation if RIU/AIU is removed from the rackmount bracket.
4. Using original screws, attach faceplate to front of mounting bracket. Attach body of RIU/AIU to rear of mounting bracket, as shown here.

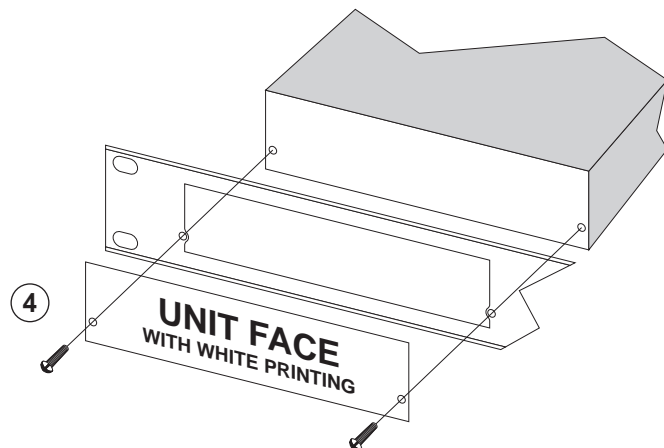

## Additional Information

Application Notes and tutorials outlining the use of RIUs with Model Builder can be found on the ASTi website (<http://www.asti-usa.com>) and on the ASTiWeb CD shipped with the system.

Note: The Application Notes and Tutorials are periodically updated; be sure to check the website regularly.

If you have questions about RIU operation and troubleshooting, please contact ASTi via email at: [support@asti-usa.com](mailto:support@asti-usa.com).

## RMA Instructions

If it becomes necessary to return equipment to ASTi for repair, please observe the following instructions:

- Obtain an RMA number either by calling ASTi or through the instructions on our website.
- Always DOUBLE BOX the equipment in question. Failure to properly package equipment could void the warranty.
- Do not include accessory pieces such as power cords, software and mounting brackets. Only send back items that do not work.
- The shipping label must include the RMA number.
- Include a description of the problem including the serial number and a point of contact. Failure to include this information could delay return of the equipment.
- If the equipment is not under warranty, a Purchase Order will be required to cover any repairs. ASTi will provide a quote for all non-warranty items.
- Equipment will be shipped back via UPS ground unless otherwise directed. If it is a non-warranty repair, shipping charges will be billed.

## DISCLAIMER

*The RIU is a sound production device. The user, by the act of installing and using the RIU and any associated equipment such as headset and speakers, warrants and represents that he/she is aware that excessive audio levels can cause permanent hearing impairment; and he/she assumes full responsibility for configuring all equipment, including hardware and software, to achieve safe operating sound pressure levels under all conditions.*

Printed in US. Copyright © 1999-2000 Advanced Simulation Technology inc.

ASTi reserves the right to change any specifications herein without prior notice.

Document No. ASSY-01-RIU04-MN-2 (Rev. 0, Apr2000)