



Advanced Simulation Technology inc.
441-A Carlisle Drive
Herndon, Virginia 20170 U.S.A.
Tel. (703)471-2104 • Fax. (703)471-2108
www.asti-usa.com

ASTi

Telestra Remote Management System

QuickStart Guide

Document: DOC-01-RMS-QS-1

Product Name: Telestra Remote Management System

ASTi ASTi Telestra Remote Management System QuickStart Guide

© Copyright ASTi 2002.

Restricted Rights: Use, duplication, or disclosure by the Government is subject to restrictions as set forth in subparagraph (c)(1)(ii) of the Rights in Technical Data and Computer Software clause at DFARS 252.227-7013.

This material may be reproduced by or for the U.S. Government pursuant to the copyright license under the clause at DFARS 252.227-7013 (1994).

ASTi

441-A Carlisle Drive

Herndon, VA 20170

Table of Contents

- INTRODUCTION** 1
- SYSTEM INSTALLATION** 1
- INITIAL NETWORK CONFIGURATION** 2
 - Default IP Addresses 2
- WEB BROWSER INTERFACE** 6
 - Pointing the Browser to RMS 6
 - Standard RMS Operation 6
 - System Login: Factory Default User ID & Password 7
- DACS SYSTEM REQUIREMENTS** 8
 - Model Builder Software 8
 - The “default.cfg” File 9
 - The “config.sys” File 10
- PROCEDURAL WARNINGS** 13
 - General Guidelines 13
 - Uploading Files 14
 - DACS Backup 15
 - DACS Restoration 15
 - Changing DACS “config.sys” File 16
 - Model Builder Virtual Screen Utility 16
- LINUX NETWORK SERVICES** 17
 - File Transfer Protocol (FTP) 17
 - Telnet 17

INTRODUCTION







This document contains a subset of the information available in the **Telestra RMS User Guide**. This QuickStart Guide, in conjunction with the online information available through RMS, should be enough to get you up and running in a timely manner.

SYSTEM INSTALLATION

After unpacking the ASTi Telestra unit, connect power, network, keyboard and monitor to the system as shown in Figure 1. For systems with a built-in CD-ROM drive, reference the “Initial Network Configuration” section for details on how to connect your network.

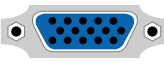
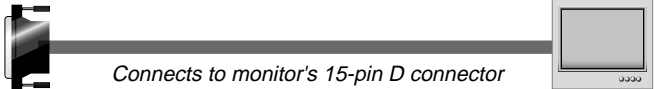
Figure 1: Telestra Connections Diagram

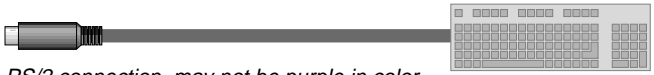
Note: As technology evolves, the Telestra 1U chassis will continue to change. Look for these objects on the rear of the chassis, and connect as appropriate.

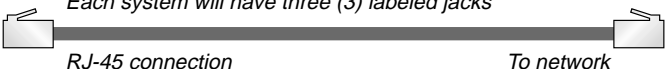
| | | |
|---|--------------------------|--|
|  | Power Cord In |  <i>To chassis</i> <i>To wall</i> |
|  | Main Power Switch | <i>May not be present on all systems</i> |
|  | Video Output |  <i>Connects to monitor's 15-pin D connector</i> |
|  | Keyboard |  <i>PS/2 connection, may not be purple in color</i> |
|  x3 | Ethernet Jack |  <i>Each system will have three (3) labeled jacks</i> <i>RJ-45 connection</i> <i>To network</i> |

Make sure the main power switch on the rear of CD-ROM-equipped Telestra systems (indicated above) is switched on. Systems without built-in CD-ROM drives have only one power switch on the front of the chassis.

Telestra RMS systems arrive with all necessary software pre-loaded. To re-build the system’s hard disk, please see Appendix A of the **Telestra RMS User Guide** (pg. 66) for the Telestra Cold Start Procedure.

Turn on the Telestra system via the power switch on the front of the chassis. The system will then boot into the Linux operating system.

Figure 3: Telestra Configuration Utility



Press the <TAB> key to move between elements (the current selection will be highlighted), or hold down the <ALT> key, and press <TAB> to reverse the toggle order.

NOTE: The Telestra system can be restarted or shut down from this screen, although these options are also available from the web-browser interface after initial network configuration.

Highlight the “Settings” option and press the <SPACE> bar or <ENTER> key to view the system’s current IP address, network gateway, and subnet mask (netmask) settings. An example is shown in Figure 4.

Figure 4: Telestra Settings Screen

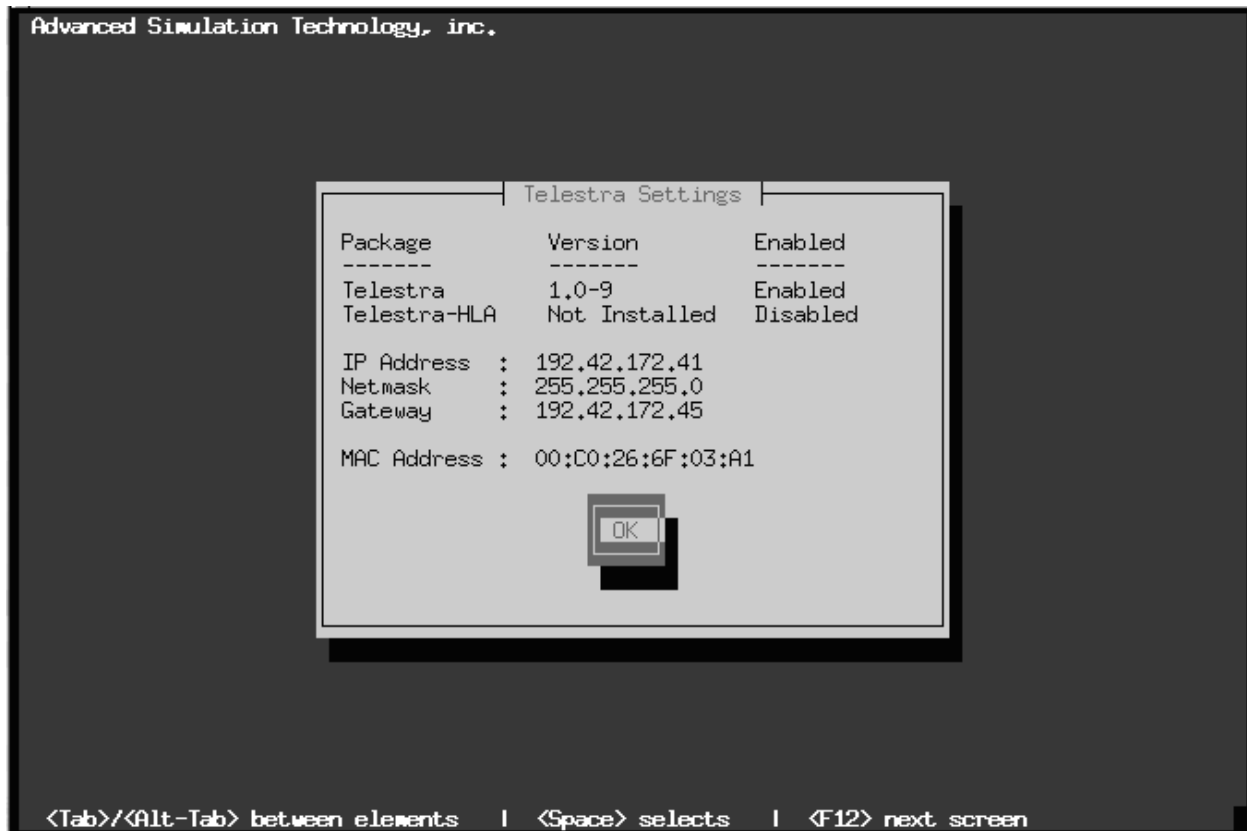

Immediately after initial system installation or cold start, these settings represent factory defaults for ethernet interface **eth0**, which may or may not be valid for the simulation network.

Press the <SPACE> bar or <ENTER> key to select “OK”, or press the <ESC> key to return to the main menu.

From the main screen (Figure 3 above), <TAB> or <ALT>+<TAB> to highlight the “Setup” element, and press the <SPACE> bar or <ENTER> key. This will display the “Change IP Settings” screen, shown in Figure 5.

Figure 5: Change IP Settings Screen

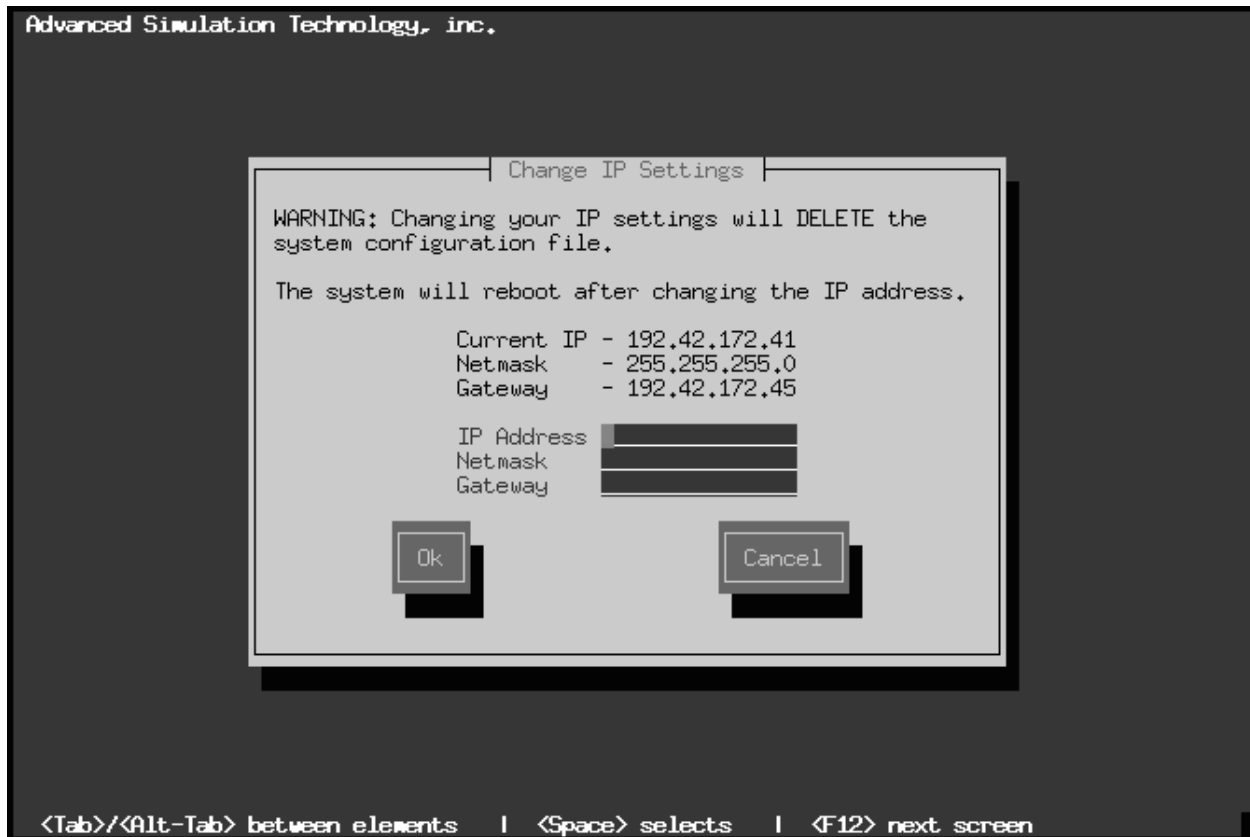

Note that this will only affect settings for ethernet card **eth0**. To change settings for eth1 or eth2, you must use RMS' web-browser interface.

Specify the desired IP address, netmask, and gateway for the simulation network, pressing the <ENTER> key after each element. If you are unsure of these settings, contact your network administrator for more information. Use the <TAB> key to highlight "OK", and press the <SPACE> bar or <ENTER> to write the settings to Telestra's hard disk; the system will then reboot. After reboot, RMS can be accessed via its web-browser interface.

WEB BROWSER INTERFACE

After RMS is configured to the proper network settings, the system can be accessed via any standard web browser on the network.

See the **Telestra RMS User Guide** (pg. 8) or online RMS information for web browser & operating system compatibility, system configuration tips, supported screen resolution, and web technology security issues.

Pointing the Browser to RMS

In order to access RMS using a web browser, the computer you use must be on the same network segment (LAN or WAN) as the RMS server itself. Contact your network administrator if you have any questions.

Launch your web browser application. In the “Address” or “Location” field of the web browser’s display, type:

```
http://xxx.xxx.xxx.xxx/
```

... where “xxx.xxx.xxx.xxx” is the IP address previously assigned to **eth0** using the Telestra Configuration Utility, described on page 5.

If this is the first time you are accessing this particular RMS server with the computer and web browser, RMS will automatically redirect you to the online “Getting Started” section.

If you have visited this RMS server before, then you will be taken directly to the standard display.

Standard RMS Operation

Most of the features available through RMS are reserved for authorized users, and system login (User ID & Password) is required. System login is **not required** to:

- View the “Getting Started” presentation.
- View software version information.
- View RMS servers on the network & their basic information.
- View Installation and Contact information for RMS servers.
- Access the RMS Help system.
- View DACS systems, including:
 - Basic information
 - Model Builder version & credits
 - Running models
 - DSPs (not DSP-specific information or statistics)
 - If applicable, RIUs connected to DSPs (again, no specific information)

Everything else is administrator-level information, and requires system login.

System Login: Factory Default User ID & Password

The factory default user ID is: **rmsuser**

The user ID is case-sensitive, and you cannot change it.

The factory default password is: **astirules**

The password is also case-sensitive, but you can change it through RMS's "Preferences" interface. This procedure is outlined in Step 2 of the Setup Tutorial (presented in the online "Getting Started" section).

Change your password! Since each RMS is shipped with the same default password, this affords virtually no security for your system. Changing your login password immediately after installation will prevent the possibility of another RMS user accessing your system.

Remember your password! If you forget your new password, the only way to recover the system (i.e., restore the factory default) is to reinstall the RMS software via the Cold Start Procedure (Telestra RMS User Guide, pg. 66).

DACS SYSTEM REQUIREMENTS

To enable a DACS system for remote management via RMS, a few DACS configuration procedures must first be followed.

Model Builder Software

DACS systems must be running Model Builder version 4.07 or higher for remote management, although ASTi recommends running version 4.09 or higher.

DACS systems must be running in “Normal Mode - RMS control”, which is the default mode (choice #1 in the DACS Startup Menu) for version 4.07 or higher on DACS system boot.

The introduction of remote DACS management has introduced some changes to the location of various DACS configuration settings.

For use with RMS, we are concerned with two ASCII text files on the DACS where various settings can be specified:

- **System Configuration File**

This file is located at

`C:\config.sys`

and will hereafter be referred to as “config.sys” for clarity.

- **Model Builder Application Configuration File**

By default*, this file is located at

`C:\mbuilder\user\models\default.cfg`

and will hereafter be referred to as “default.cfg” for clarity.

**Although users can force the Model Builder software to load different Model Builder Application Configuration Files (all of which end in the “.cfg” file extension), that procedure will not be covered here, and all of the changes presented here in reference to “default.cfg” also apply.*

Also, for the sake of clarity, ethernet network interfaces will hereafter be referred to as “ethernet cards”, since the majority of network parameters discussed in this section refer to hardware settings; “network interface” is a little too esoteric for this discussion.

The “default.cfg” File

To allow remote management, the “default.cfg” file loaded by the Model Builder software *must* contain the following line:

```
CELL=ON
```

Network settings that specify the following *hardware parameters* should be removed—or disabled by placing a semicolon (;) as the first character of the line—from the “default.cfg” file:

- Number of ethernet cards
- DIS/HLA ethernet card
 - local IP address
 - subnet mask
 - gateway IP address
- Host ethernet card
 - local IP address
 - subnet mask
 - gateway IP address

These settings should now be specified in the “config.sys” file, described in the next section.

IMPORTANT: Specifying the above hardware parameters in the “default.cfg” file will override similar settings in the “config.sys” file.

All other network commands (port settings, DIS or HLA settings, etc.) should continue to reside in “default.cfg”; this has not changed.

See Appendix B of the **Telestra RMS User Guide** (pg. 70) for an example installation.

The “config.sys” File

The hardware settings for the DACS system’s ethernet cards are now specified in the “config.sys” file, along with a couple of other RMS-specific parameters. All of the settings listed here can be changed via RMS’ web-interface. The following information explains the individual settings; examples of properly configured “config.sys” files are included at the end of this section.

Other than the settings outlined here, DO NOT change any other lines in the “config.sys” file unless specifically instructed to do so by ASTi.

[mbremote]

This section of the “config.sys” file specifies two RMS parameters: the IP address of the managing RMS server, and which DACS directory to load on system boot. DACS system ethernet card settings are handled in the [common] section, described on page 11.

SET REMOTE=<ipAddress>

<ipAddress> is the IP address of the RMS server that will manage this DACS system.

Changing this setting in the DACS “config.sys” file will not change the IP address of the RMS server itself.

SET MODELS=<directory>

<directory> is the directory that the Model Builder software will load as its “current working directory” on system boot. For example, if this is set to “USER”, Model Builder will start using:

```
C:\mbuilder\user\models
```

as the current working directory, and will load the file:

```
C:\mbuilder\user\models\default.cfg
```

as the Model Builder Application Configuration File.

Performing a DACS restoration via RMS will increase the number of candidate directories for this setting. For example, a DACS restoration performed using a backup file generated on January 3, 2001, will create a directory on the DACS hard disk named:

```
C:\mbuilder\03jan01
```

Setting the “SET MODELS=” parameter to “03JAN01” will cause Model Builder to start using:

```
C:\mbuilder\03jan01\models
```

as the current working directory, and will load the file:

```
C:\mbuilder\03jan01\models\default.cfg
```

as the Model Builder Application Configuration File. Remember, ethernet card hardware settings specified in any “default.cfg” file will override similar settings in “config.sys”. After performing a DACS restoration, it is important to verify that settings in the new “default.cfg” do not override the system’s “config.sys” file.

[common]

This section of “config.sys” handles the ethernet card hardware configurations for DACS systems. In Model Builder versions 4.07 and higher, the ethernet card settings listed below pertain to DACS systems running in remote mode (system default), and non-remote mode alike. Each of the parameters listed below can be changed via RMS. Remember, similar settings in the “default.cfg” file will override these “config.sys” parameters.

DACS Systems with One Ethernet Card**SET LOCAL_IP=<ipAddress>**

<ipAddress> is the IP address for the DACS system’s single ethernet card.

SET GATEWAY=<ipAddress>

<ipAddress> is the gateway IP address for the DACS system’s single ethernet card.

SET SUBNET_MASK=<netmask>

<netmask> is the subnet mask for the DACS system’s single ethernet card.

DACS Systems with Two Ethernet Cards**SET LOCAL_IP=<ipAddress1>,<ipAddress2>**

<ipAddress1> is the IP address for the DACS system’s *host* ethernet card.

<ipAddress2> is the IP address for the system’s *RMS/DIS/HLA* ethernet card, and is the IP address to configure in RMS for DACS discovery. Separate the two with a comma (,).

Please note that specifying only <ipAddress2>, such as:

```
SET LOCAL_IP=, <ipAddress2>
```

is not a valid “config.sys” command.

SET GATEWAY=<ipAddress1>,<ipAddress2>

<ipAddress1> is the gateway IP address for the DACS system’s *host* ethernet card.

<ipAddress2> is the gateway IP address for the system’s *RMS/DIS/HLA* ethernet card. Separate the two with a comma (,).

Again, specifying only <ipAddress2>, such as:

```
SET GATEWAY=, <ipAddress2>
```

is not a valid “config.sys” command.

SET SUBNET_MASK=<netmask1>,<netmask2>

<netmask1> is the subnet mask for the DACS system’s *host* ethernet card.

<netmask2> is the subnet mask for the system’s *RMS/DIS/HLA* ethernet card. Separate the two with a comma (,).

Again, specifying only <ipAddress2>, such as:

```
SET SUBNET_MASK=, <ipAddress2>
```

is not a valid “config.sys” command.

See Appendix B of the **Telestra RMS User Guide** (pg. 70) for an example installation.

Single Ethernet DACS “config.sys” Example

In this example, the DACS system has one ethernet card.

```
[menu]
...
[mbremote]
SET SYSTEM=DEFAULT
SET MODELS=USER
SET REMOTE=192.168.100.101
...
[common]
SET LOCAL_IP=192.168.100.5
SET GATEWAY=192.168.100.100
SET SUBNET_MASK=255.255.255.0
...
```

Dual Ethernet DACS “config.sys” Example

In this example, the DACS system has two ethernet cards; one is the host ethernet card, the other is the RMS/DIS/HLA ethernet card. In the sample file below, **host card settings are in bold**.

```
[menu]
...
[mbremote]
SET SYSTEM=DEFAULT
SET MODELS=USER
SET REMOTE=192.168.100.101
...
[common]
SET LOCAL_IP=192.168.212.51,192.168.100.5
SET GATEWAY=192.168.212.254,192.168.100.100
SET SUBNET_MASK=255.255.255.0,255.255.255.0
...
```

In this dual ethernet example, specify 192.168.100.5 as the DACS IP address in the RMS configuration utility. Otherwise, it will not be successfully discovered.

Other than the settings outlined here, DO NOT change any other lines in the “config.sys” file unless specifically instructed to do so by ASTi.

See Appendix B of the [Telestra RMS User Guide](#) (pg. 70) for an example installation.

PROCEDURAL WARNINGS

General Guidelines

- **DO NOT** create local files on the DACS system (e.g., recording soundfiles or saving models) while in remote mode. **Remember, remote mode is the Model Builder default.**

If you wish to create local files on the DACS system, ASTi recommends loading Model Builder in non-RMS mode. This is choice #2 from the Startup Menu: “Normal Operation - without RMS”, which is available on DACS system boot.

- Working with Model Builder (either via directly-connected keyboard/monitor, or over the Model Builder Virtual Screen utility) will suspend the ability to restart the software. A red “RestartOff” alert message will be displayed at the bottom of the MB screen.
- Initiating a DACS backup or restore will put its Model Builder software into a freeze state (as if the F3 key had been pressed).
- Pressing the F3 key on the DACS keyboard, or over the Model Builder Virtual Screen utility, will un-freeze the software.

This could result in an unsuccessful DACS backup/restore and/or erratic DACS behavior.

This allows the user to recover from a network communications failure, as the DACS system will not automatically un-freeze in this situation.

- RMS will only allow one (1) DACS system to be backed-up or restored at a time. If a DACS backup or restore is in progress, any attempt to initiate a backup or restoration for any other (or the same) DACS system will be unsuccessful. DACS systems managed by a different RMS server will not be affected.
- DACS single file access (viewing, downloading, uploading) is disabled for **all** DACS systems managed by an RMS server during a DACS backup or restoration. DACS systems managed by a different RMS server will not be affected.

Uploading Files

Various procedures in RMS require you to upload files to the RMS server. These include:

- Uploading an Options File
- Uploading an RMS Configuration File
- Uploading a DACS backup file for restoration
- Uploading a file to a DACS' file system

Depending on the computer and web browser that you are using to access RMS, when you click on the "Browse..." button to upload a file, you may seemingly be unable to locate the desired file on your computer. This happens because the RMS and DACS systems use unique file extensions such as ".opt", ".conf", ".cfg", etc.

Using Windows95/98/2000/ME/NT with either Netscape or Internet Explorer

In the dialog box that pops up after clicking the "Browse..." button, locate the pull-down menu labeled "Files of type". This may default to "HTML Files (*.htm,*.html)". Click on the pull-down menu, and select "All Files (*.*)". This will allow you to access every kind of file on your computer.

Also, when uploading files that **MUST** be named a certain way in order to work (e.g., "telestra.opt" or "telestra.conf"), be aware that the Windows operating system may try to force capitalization to "Telestra.opt" or "Telestra.conf" in the upload form. You should first click "Browse..." to locate the file, then click "OK". ***Check the filename in the slot of the upload form before clicking "Upload File" button!*** If capitalization has been forced, change the filename to all lower-case letters ***in the slot on the form*** before uploading. Failure to maintain all lower-case filenames for these files will result in RMS not recognizing that they have been uploaded.

Using Linux systems (with KDE or Gnome) running Netscape

In the dialog box that pops up after clicking the "Browse..." button, locate the "Filter" section. If it has a wildcard (*) with a file extension (e.g., "/home/me/*.html") anywhere in that field, you should remove the "*.html" (or "*.whatever"). This will allow you to access every kind of file on your local file system. If you're running Mozilla (not recommended), look for the "Files of type" menu, and make changes as described in the Windows section above.

Using MacOS with either Netscape or Internet Explorer

Users should be able to access any file on their system without making any changes to the pop-up dialog box.

DACS Backup

- Only initiate a DACS backup if you are certain that nobody is using its Model Builder software.
- **DO NOT** change the names of DACS backup files generated by RMS if you plan to later restore from them.

Backup file names are based on the IP address of the DACS, and the date of the backup. For example, backing up a DACS system with IP address “192.168.10.10” on June 7th, 2001 will result in a backup file named “192.168.10.10_07Jun01.tgz”.

During DACS restoration, the date contained in the backup file’s name will be used as the target directory name on the DACS hard disk. Using “192.168.10.10_07Jun01.tgz” as the source of a DACS restoration will create the directory

```
C:\mbuilder\07jun01\
```

on the DACS hard disk, and all backed-up files will be restored therein.

- Performing multiple backup procedures for a DACS on the same day will result in the previous backup file being over-written on the RMS file system (they will have the same file name).
- The backup process can **ONLY** be cancelled from the “Working” screen (with the animated clock). Clearing the system’s lock files via the “Management” screen in RMS (see page 62 of the **Telestra RMS User Guide** for more information) will only release the system’s lock status, and will result in incomplete/unsuccessful backup files.

DACS Restoration

- Only initiate a DACS restoration if you are certain that nobody is using its Model Builder software.
- Uploading previous backup files for DACS restoration using certain OS/browser combinations may result in the dots of the file name being replaced by underscores (e.g., “192.168.10.10_07Jun01.tgz” may become “192_168_10_10_07Jun01.tgz”). This **will not** affect your ability to restore from the file.
- During DACS restoration, the date contained in the backup file’s name will be used as the target directory name on the DACS hard disk. Using “192.168.10.10_07Jun01.tgz” as the source of a DACS restoration will create the directory

```
C:\mbuilder\07jun01\
```

on the DACS hard disk, and all backed-up files will be restored therein.

- After successful DACS restoration, in order to run Model Builder with the newly-restored data, the “SET MODELS=” parameter of the “config.sys” file must be changed.

Change “SET MODELS=” by manually editing the “config.sys” file in DOS (see page 10 for command specifics). Then reboot the DACS.

Or, change “SET MODELS=” for that DACS via RMS’ “DACS Configuration” screen. The DACS system will automatically reboot.

- Performing multiple DACS restorations from the same backup file will over-write any information from the previous restoration process (they will create and write into the same directory on the DACS hard disk).
- The restoration process can *ONLY* be cancelled from the “Working” screen (with the animated clock). Clearing the system’s lock files via the “Management” screen in RMS (see page 62 of the **Telestra RMS User Guide** for more information) will only release the system’s lock status, and will result in an incomplete/unsuccessful restoration.

Changing DACS “config.sys” File

- **DO NOT** attempt to change settings in the “config.sys” file through RMS or at the DOS command line during DACS backup or restoration; this could result in failure of the running process.

Model Builder Virtual Screen Utility

The Model Builder Virtual Screen (MBVS) utility consumes a considerable amount of network bandwidth. This happens because keyboard commands must be sent from Telestra to the DACS system, and screen information must be passed back... in real time, and over the network.

Because MBVS runs as a higher-priority process on the Telestra system, the web-based Remote Management System (RMS) may be less responsive during MBVS operation.

Because of extra network traffic that MBVS creates, audio and communications clipping may occur during its use.

- **DO NOT** attempt to access Model Builder software through MBVS during a backup or restoration process for that DACS system.
- Model Builder only supports the display of one screen at a time. A user working with Model Builder through directly-connected keyboard and monitor will see (and can only access) the exact same screen as one using the software over MBVS.

LINUX NETWORK SERVICES

File Transfer Protocol (FTP)

Telestra systems support standard FTP for downloading DACS backup files, or uploading files for DACS restoration. Telestra *does not* support anonymous FTP.

The FTP user ID is: **ftpuser**

The FTP password is: **astirules**

This login information is case-sensitive, and *is not* user-configurable.

Logging into Telestra via FTP will put you into the

```
/home/ftpuser
```

directory. Simply change into the “MBBackup” sub-directory

```
/home/ftpuser/MBBackup
```

to upload or download files.

Telnet

Telestra systems with RMS do not support telnet; there is no system login.