



Advanced Simulation Technology inc.
500 A Huntmar Park Drive
Herndon, Virginia 20170 U.S.A.
Tel. (703)471-2104 • Fax. (703)471-2108
www.asti-usa.com

ASTi

Digital Audio Communication System (DACS)

Operation & Maintenance Manual

Document: DOC-01-DACS-OM-4

ASTi ASTi Digital Audio Communication System Operation & Maintenance Manual

© Copyright ASTi 1989-2006.

Restricted Rights: Use, duplication, or disclosure by the Government is subject to restrictions as set forth in subparagraph (c)(1)(ii) of the Rights in Technical Data and Computer Software clause at DFARS 252.227-7013.

This material may be reproduced by or for the U.S. Government pursuant to the copyright license under the clause at DFARS 252.227-7013 (1994).

ASTi

500A Huntmar Park Drive

Herndon, VA 20170

Table of Contents

Introduction	1
Chapter 1: General Information	2
Safety Precautions	2
Equipment Handling	2
Limited Warranty	3
Customer Support	4
Chapter 2: System Description	5
Digital Audio Communication System Description Overview	5
DACS Platform Descriptions	7
DACS Hardware Components	8
DACS Software	16
Chapter 3: Preparation for Use	21
Receiving and Unpacking	21
Parts Inventory	21
System Installation	22
Chapter 4: DACS Operation	30
Powering the DACS Up and Down	30
DACS Software	31
Model Generation and Operation Overview	35
Network Interface	40
Chapter 5: Test and Maintenance	42
MTBF and MTTR	42
Tools and Test Equipment	42
Spare Equipment	42
Preventative Maintenance	44
Troubleshooting	45
Remove and Replace	53
Returns	60
Cold Start	61
Model Builder Software Updates	65
Appendix A: Interface Definition	66
Model Processor Interface	66
Waveform Synthesizer Interface	67
TDM Controller Interface	68
Remote Interface Unit	68
Network Interface	70
I/O Interface	70
Appendix B: Mechanical Layouts	72
2U Chassis Mechanical Layout	72
4U Chassis Mechanical Layout	74
MicroDACS Chassis Mechanical Layout	76
RIU Version 4.1 Mechanical Layout	77
Distributed Digital Interface Mechanical Layout	78
Mechanical Layout AIU	79

Appendix C: Common Problems	80
Problems with Waveform Synthesizer Audio I/O	80
RIU Problems	82
Miscellaneous Problems	83
Appendix D: System Specifications	84
Temperature And Humidity Requirements	84
Chassis Cooling	84
System Weight	84
Reliability	84
Appendix E: Cold Start Support	85
AMI BIOS (c) 1992 Setup (486 Systems)	85
AMI BIOS (c) 1995 Setup (586 Systems)	86
AMI BIOS (c)1996 Setup (586 Systems)	87
Half-Length CPU (1) Award BIOS Setup	88
AMI BIOS (c)1998 Setup (586 Systems)	89
Micro-Star 6163 BXMaster BIOS Setup	90
Advantech PCA-6178 BIOS Setup	91
MiniDACS: JUKI-3711PT BIOS Settings	92
MiniDACS: JUKI-3711PTN BIOS Settings	93

Introduction

The Operation and Maintenance Manual provides basic operation, testing, and maintenance information about your Digital Audio Communication System (DACS). Chapter 1 discusses general topics, such as safety considerations, equipment handling, system warranty, and customer support. Chapter 2 provides an overall description of the DACS including hardware and software components. Chapter 3 discusses preparation of the DACS for use, including unpacking procedures, hardware and software installation, and external equipment connection. Chapter 4 discusses general DACS operation such as powering up and down, Model Builder sound model generation software operation, DACS communications, and operation of external equipment. Chapter 5 provides details on DACS maintenance and testing, including preventative maintenance procedures, fault isolation procedures, daily readiness testing, and cold start procedures. Appendices provide various technical and support information including mechanical and electrical interfaces, system operating specifications, cold start information, error codes, and FAQs.

For an in-depth explanation and understanding of the Model Builder sound model generation software included with your DACS, consult the Model Builder Reference Guide.

Chapter 1: General Information

This chapter provides general information about your Digital Audio Communication System (DACS). Topics include system hardware and software description, safety precautions, warranty, and customer support.

Safety Precautions

This section must be read completely and understood before using the Digital Audio Communication System. If you are unsure of any information presented please contact ASTi. Methods of contact are listed at the end of this chapter.

The following safety precautions must be observed when performing any operation and maintenance tasks associated with the ASTi Digital Audio Communication System (DACS). These safety precautions are necessary to prevent injury to personnel and damage to equipment.

**** WARNING ****

Potentially fatal voltages are present in the Digital Audio Communication System. Before removing, handling, or replacing any DACS component, ensure that ALL electrical supplies have been turned off and electrical power cords disconnected from the Digital Audio Communication System.

The following disclaimer is provided regarding use of the DACS. The disclaimer applies to all parties using the DACS in any situation or configuration. This disclaimer should be read and understood completely before using the Digital Audio Communication System.

**** DISCLAIMER ****

The DACS is a sound production device. The user, by the act of installing and using the DACS and any associated equipment such as external amplifiers, headsets, speakers, etc., warrants and represents that he/she is aware that excessive audio levels can cause permanent hearing impairment and that he/she assumes full responsibility for configuring all equipment including hardware and software to achieve safe operating sound pressure levels under all conditions.

Equipment Handling

All Digital Audio Communication System Circuit Boards and Modules are sensitive to electrostatic discharge (ESD). To avoid damage to DACS equipment, proper ESD procedures should be followed when handling all Digital Audio Communication System equipment. If it is necessary to remove and/or replace a circuit board or module, follow the procedures listed in Chapter 5, Test and Maintenance.

Ensure that all work is performed at a properly grounded ESD work station. In addition, all personnel handling DACS equipment should be properly grounded.

When transporting or shipping individual modules, equipment should be fully enclosed in an anti-static bag.

ASTi is not responsible for equipment damage due to improper handling.

Limited Warranty

Warranty

ASTi provides a one year limited warranty on all ASTi equipment covering all parts and labor.

In the case of equipment upgrades, warranty applies to original date of shipment of individual components.

Other commercial equipment purchased or provided such as monitors, amplifiers, speakers, fiber optic links, etc. are also covered under the one year warranty unless otherwise stated.

The warranty does not cover improper equipment handling or improperly packaged returns.

Extended warranties are available. Contact ASTi for details.

Repairs and Returns

If it becomes necessary to return equipment to ASTi please observe the following instructions:

1. Obtain an RMA number through ASTi's website: <http://www.asti-usa.com/support/>
2. When packaging the equipment in question, make sure it is well protected. The device should be properly enclosed in an antistatic bag to prevent possible ESD damage. Failure to properly package the equipment during shipping could void the warranty.
3. Do not include accessory pieces such as rack mount kits, power supplies or software. Only send items that do not work.
4. The shipping label must include the RMA number.
5. Include a description of the problem, point of contact, phone number, return address and unit serial number(s). Failure to include this information could extensively delay the return of the equipment.
6. Evaluation of equipment is performed free of charge. No work will be done without prior customer approval. Customer is responsible for shipping charges to ASTi for warranty and non-warranty repairs.
7. If an RMA number is not used within sixty (30) days of issuing date, the request data and number issued will be closed and designated as unused.
8. Any items received from customers without RMA numbers or appropriate contact information included with shipment will not be tested. After sixty (60) days, ASTi reserves the right to scrap all hardware received in this condition.
9. If the equipment is not under warranty a Purchase Order will be required to cover the cost of any repairs. ASTi will provide a quote for all non-warranty repair items.
10. Equipment will be shipped back using Federal Express, unless otherwise directed. If the repair is non-warranty then shipping charges will be billed.
11. **International customers** must include the correct product value on all shipping documents. Contact ASTi for proper harmonized tariff codes. The customer is responsible for all duties, taxes and fees incurred in shipment of the equipment.

Customer Support

Customer support is a major part of the ASTi audio simulation solution. If you have any questions about our product, how it can be used for your application, or suggestions for future enhancements, you can contact ASTi in the following ways:

By E-mail. Send an email any time to us at support@asti-usa.com.

By Web. You can reach us through the World Wide Web at www.asti-usa.com.

By Fax. Include your name, company, fax number, phone number where you can be reached, and your specific question. The fax number for ASTi is (703) 471-2108

By Phone. Call the technical support line 9:00am to 5:00pm (Eastern) weekdays with your question. Someone will be happy to assist you. The number is (703) 471-2104.

By Mail. Include your name, company, fax number, phone number where you can be reached, and your particular question. Mail to the following address:

**ASTi
500A Huntmar Park Drive
Herndon, VA 20170
USA**

Chapter 2: System Description

This chapter describes the different Digital Audio Communication System (DACS) hardware components and typical system configurations.

Digital Audio Communication System Description Overview

The ASTi Digital Audio Communication System (DACS) is a fully integrated DSP based system designed to provide a total solution to all aspects of the sound simulation environment including aural cueing, intercom, navigational beacon and radio communication simulation, inter-trainer networked radio and intercom, Distributed Interactive Simulation (DIS) compatible communications, caution/warning tones, RWR and ECM equipment audio, as well other audio simulation components.

Included with the DACS is the ASTi Model Builder sound model generation software which allows the user to build, test, and modify aural cue and communications sound models quickly and easily without resorting to any DSP or high level software language programming.

When constructing sound models, the user selects the sound objects required for the specific sound simulation from the Model Builder menus and inserts them into the sound model. Sound Objects include various types of sound, mixing and control objects such as engines, radios, mixers, communication panels, waveforms, input controls, functions, balancers, etc. The user can connect these objects, set parameters locally, or connect parameters to host input controls. Sound models can then be tested, tuned, and modified in real time.

Depending on configuration, the DACS is capable of simultaneously running several user defined audio simulation models at one time. Each model consists of groups of user selected sound sources, mixers, and controls which generate the desired audio simulation. Models may also be connected, allowing growth and expansion of model complexity and capability.

For large applications such as those involving multiple networked training devices or large numbers of operators, multiple DACS units may be employed to achieve an overall networked communications simulation solution.

There are two main processing components in the Digital Audio Communication System hardware platform, the main CPU or Model Processor and the Audio Processor(s). Audio processor components consist of Waveform Synthesizers and TDM (Time Division Multiplex) Controllers. A DACS may have multiple audio processor components.

The Model Processor runs the Model Builder sound model run time and development environment and much of the higher level sound model control. This includes such functions as reading input data from the host, calculating and updating mixing gains, frequencies and control values for each sound, mixing, or control object in the sound model(s), generating navigation identifier keying, calculating radio parameters and signal effects, etc.

Waveform Synthesizers incorporate a Digital Signal Processor (DSP), and depending on the synthesizer configuration, up to eight analog input and eight analog output channels. Analog audio channels are connected directly to the card local to the DACS. The Waveform Synthesizer DSP runs the signal processing algorithms associated with each sound model, such as waveform generation, sound file sample and playback, voice mixing, etc.

The TDM Controller performs all the functions of the Waveform Synthesizer, but instead of analog inputs and outputs, it sends and receives sound in digital form across a TDM ring to one or more Remote Interface Units (RIUs). The RIUs handle all the D/A and A/D conversions, some local mixing, as well as a few digital inputs and outputs primarily for PTT (Press-To-Talk) and PTR (Press-To-Radio) sense/activation.

The RIU also provides two serial ports for connection of hand held terminals or custom hardware panels. This interface allows either direct connection of both simulated and real communications control panels to the DACS equipment to help achieve a total end to end solution.

Depending on the application, the DACS may also have one or more network interface cards. The network interfaces provide for a number of features including:

- Connection of one or more host simulation computers providing simulation state parameters and simulated tactical data link information for driving the local communications and environmental sound model(s)
- Interface to a DIS or HLA network providing network communications and radio propagation effects between ASTi DACSs or other DIS compatible equipment

I/O cards and modules are also available to provide extra digital and analog I/O capability for interface of switches and controls directly to the DACS.

A typical DACS configuration depends on the system application, but in general includes a Model Processor, Power Supply, one or more Waveform Synthesizers or TDM Controllers with RIUs, a Host Interface (used for host connection, terrain server connection, and model server connections) and possibly a DIS or HLA interface. Software includes the Model Builder Basic development and runtime environment and any software options chosen by the user. For sound model construction and tuning, as well as diagnostic test analysis, a monitor and keyboard are also provided with most DACS platforms.

A typical Digital Audio Communication System configuration is shown in Figure 1.

Figure 1: Typical Digital Audio Communication System

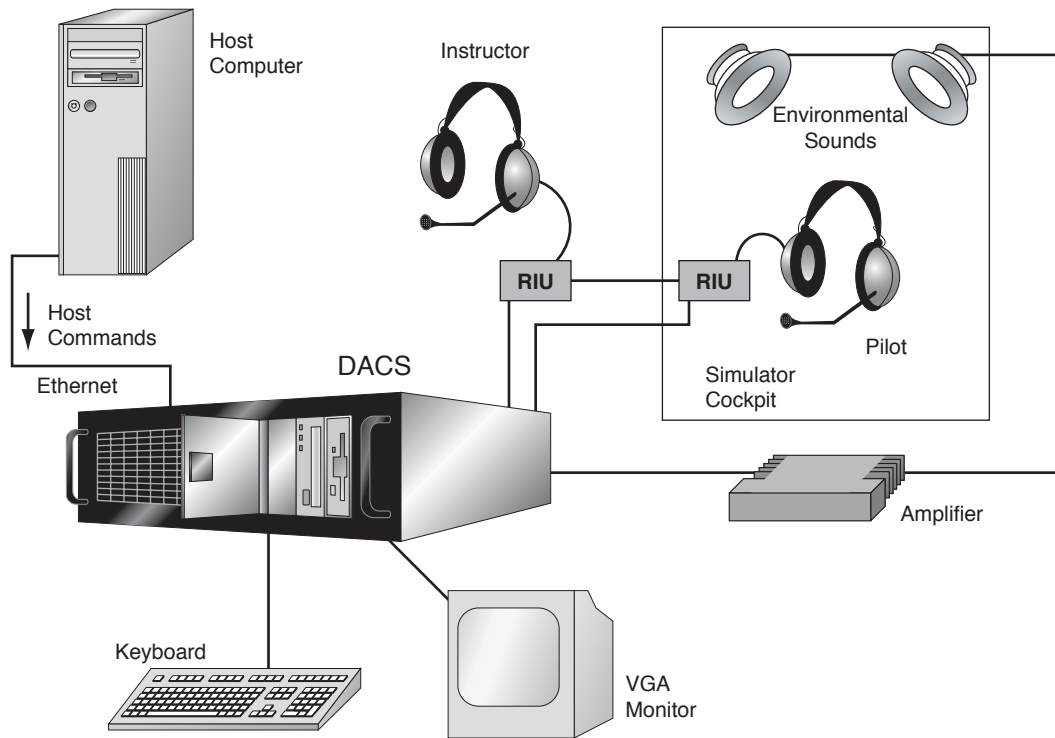

DACS hardware and software components are described in more detail in the following sections.

DACS Platform Descriptions

ASTi offers several available chassis options for the DACS processing nodes.

2U Chassis

The standard and most-commonly purchased DACS is based on a 2U-high (3.5"), 19" rackmount industrial chassis. Individual circuit cards are inserted into a passive backplane with access from the rear of the chassis.

4U Chassis

An optional chassis upgrade is available to convert from a 2U to a 4U-high (7") rackmount chassis with a wider backplane and greater expandability.

MicroDACS

This chassis offers a small installation footprint, light weight, and low power consumption. A single, PC/104-based TDM card is available in this system. A removable media module (Compact-Flash™ or Microdrive™) acts as the system hard drive.

DACS Hardware Components

The 2U and 4U DACS processing nodes consist of a number of hardware components, and can be configured in many different ways depending on the requirements of the particular application. Components available include the main model processor, various audio processors such as Waveform Synthesizers, TDM controllers, Remote Interface Units, Distributed Digital Interfaces, network interfaces such as the Host Interface and DIS/HLA Interface, and general purpose I/O including Digital Inputs, Digital Outputs, and Analog Inputs.

The MicroDACS uses a single TDM controller, Remote Interface Units, Distributed Digital Interfaces, and a dual network interface card.

These components are discussed in more detail in the following sections.

Engineering drawings are supplied with each DACS which identify the overall system configuration as well as each line-replaceable component. Additional documentation is included with individual Remote Interface Units and Distributed Digital Interfaces.

Chassis

The 2U and 4U chassis are supplied with rackmount brackets for mounting in a 19"-wide rack. The power switch, floppy drive, and reset switch on the front of the chassis; monitor, keyboard and power cord connectors are in the back.

All 2U and 4U chassis come with PCI backplanes to support 10/100Mbps auto-sensing ethernet cards.

The MicroDACS can be rackmounted using a 2U-high bracket, which accommodates two (2) MicroDACS', and must be purchased separately.

Power Supply

Power supply specifications may vary slightly between platforms. In general, however, the power supply is a standard 250 watt PC-style power supply. The supply accepts 120V/60Hz, and can also be configured to accept overseas voltages such as 220V/50Hz. Some platforms contain a switch on the rear of the chassis in the vicinity of the power supply which must be set for the proper voltage. Other systems will have an autosensing supply indicated by a label on the rear of the chassis.

Model Processor

The model processor is the main processing unit for the DACS processing node. In 2U and 4U systems, the model processor includes the chassis, power supply, hard drive, floppy drive, and CPU.

CPU type, memory size, and hard disk size vary from system to system. Consult your DACS engineering drawings to determine the configuration of the model processor installed in your system.

ASTi's Model Builder model generation software as well as support software such as a DOS operating system and disk caching routines are installed and operate on the model processor.

During DACS operation, the model processor runs the Model Builder software environment and the audio simulation models developed by the user.

Memory installed varies from system to system depending on the requirements. Larger amounts of memory provide more cache area for sound recording and playback as well as additional sound model memory.

Each system has a CPU reset button for hard reboot of the model processor. The reset button is located on the front of the chassis.

**** WARNING ****

The reset button should only be used to reboot the Model Processor if there is a complete CPU or operating system failure and the keyboard is inoperative. At all other times, simultaneously press [ctrl][alt][del] to reboot. Using the reset button during DACS operation can prevent recorded audio data buffered in cache memory from being written to disk before system reset, resulting in loss of data.

CPU

The CPU type used in the system depends on the time of purchase and whether any CPU upgrades have been incorporated. The typical CPU is an Intel- or AMD-based Pentium processor.

Hard Drive

On most DACS, the hard drive is a fixed drive of at least 7GByte in size. Larger drive options are available at time of purchase or as upgrades. Applications with a large number of recorded sounds, or applications that record voice communications to the hard disk, will require more hard drive space.

Removable drive options are also available. Platforms with removable drives will include a removable drive docking bay as part of the chassis. The bay will accommodate a 3.5” removable drive cartridge which must be purchased through ASTi to ensure proper operation

Fixed drives are standard on all platforms, with removable drives available as options.

For systems with a removable drive, the removable cartridge containing the drive must be ordered separately. Size is generally 7GByte or larger. Size options and upgrades are also available.

Specially configured record platforms may have a high-performance SCSI drive with a caching controller.

Floppy Drive

Floppy drives are standard on 2U and 4U systems. The drive is a standard 1.44MB, 3.5” floppy disk drive.

Monitor and Keyboard

A 101-key keyboard are supported by the 2U and 4U platforms via PS/2 connector on the rear of the chassis on the CPU card; the MicroDACS requires a USB keyboard. Keyboards must be purchased separately. Legacy DACS may have the older, AT-style keyboard connections on the front or rear of the chassis.

The video connection is via a 15-pin, female, high-density, sub-miniature, “D” style connector located on the back of the chassis. It supports a standard SVGA or multisync monitor, also purchased separately.

Waveform Synthesizers

Waveform Synthesizers perform sound model digital signal processing and provide analog input and output interface for external equipment such as speakers, headsets, and microphones.

Each individual Waveform Synthesizer contains a single DSP and performs all the signal processing associated with a specific, user developed, sound model. The Waveform Synthesizer provides up to eight channels of analog inputs and outputs (eight inputs and eight outputs) for interfacing to external audio equipment. Converters are 16 bit delta sigma with sample rate tracking anti alias filters which provide excellent sound quality.

Interface to external audio equipment such as headsets, mics, amplifiers, etc. is via a 37 pin, female “D” connector located in the rear of the chassis. Connector pin-out is shown in Appendix A and on the Waveform Synthesizer Engineering Drawing supplied with your DACS.

Analog inputs are full differential (balanced) and accept signal levels up to a maximum of 3Vp-p. A preamp stage with gain adjustment from 0 - 60dB is included on each input. Gain values are set using command lines in the Model Builder start-up configuration file and can also be set through the Model Builder software runtime environment directly. Maximum analog output levels are approximately 5Vp-p into 600 Ohm or larger loads.

External audio equipment such as microphones, headphones, and speakers are connected to the Waveform Synthesizer inputs and outputs either directly or through appropriate amplifiers and preamplifiers as required.

Sample Rate: DSP sample rates on the Waveform Synthesizer are set by the user through the Model Builder software environment. Sample rates range from 8kHz to 48kHz. Since the anti-aliasing filters are sample rate tracking, no hardware reconfiguration is required when sample rates are changed.

Interconnection: A high speed communication port connection is provided on the Waveform Synthesizer. This port provides the capability to link up to three cards together, enabling sounds and communications generated on one processor to be accessed by or mixed with the sounds and communications generated by another processor.

A typical configuration is connection of two Waveform Synthesizers. Connection of the two cards allows audio inputs and sounds generated on one card to be mixed into outputs on the other card.

This high speed communications link between Waveform Synthesizers is made through a 40 pin header on the top of each card or module. For multiple card-to-card connection, one 40 conductor ribbon cable is installed and connected to all cards that need to pass sound between them.

In addition to linking hardware, you will also need to properly configure sound models running on the DACS. For information about linking your sound models see the Global Channels section in the Model Builder Reference Manual.

TDM Controller

The TDM Controller along with its associated Remote Interface Unit (RIU) components provide similar functionality to the Waveform Synthesizer but with greater expandability and flexibility.

The TDM Controller itself, has the same DSP processing capabilities as the Waveform Synthesizer and is also physically mounted in the main DACS chassis.

Instead of providing analog interfaces local to the card, however, the TDM Controller forms a base driver for a Time Division Multiplex ring. This ring carries digital audio to and from Remote Interface Units populating the ring. The RIUs in turn provide the analog to digital interface at remote sites along the ring. See the next section for more information on the RIU.

The TDM Controller has two RJ-45 connectors for connection of standard Category 5, UTP network cables. To form the TDM ring, cabling is run from the TDM controller card to the first Remote Interface Unit. Subsequent RIUs are daisy chained together with the ring eventually terminating back at the TDM Controller (see Figure 2). Rings can be configured to a maximum length of 100m.

Within the Model Builder software environment, a TDM controller looks exactly like a Waveform Synthesizer. Sound and communications models are developed in the same fashion. The main difference is that models generated for a TDM Controller allow up to 24 audio ins and outs as opposed to 8 ins and outs with the Waveform Synthesizer.

Figure 2: TDM Ring Distributing Digital Audio

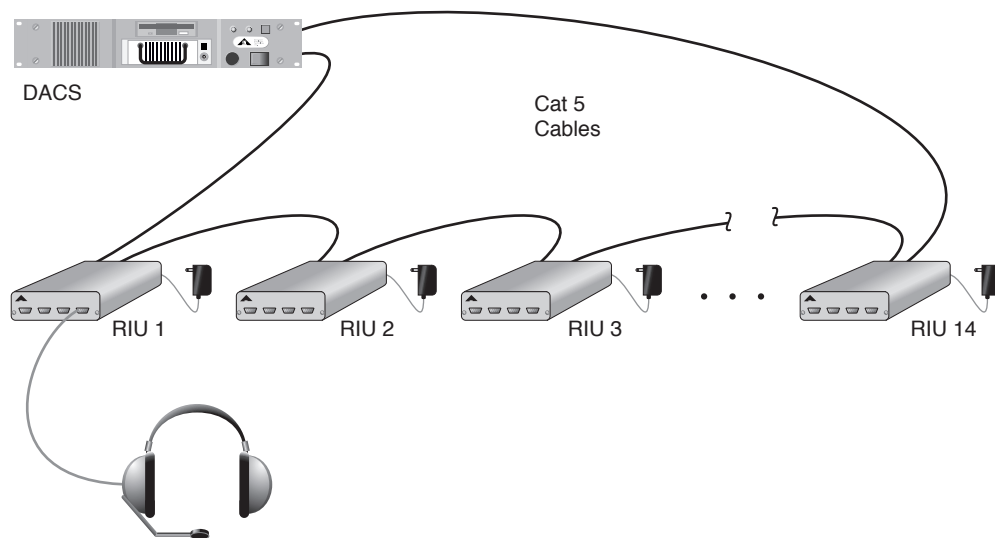

Audio interface within the TDM architecture is via the Remote Interface Unit (RIU). RIUs contain both signal conditioning circuitry as well as the necessary A/D and D/A converters for conversion of audio between the digital and analog domain. Audio sampled by RIUs distributed on the TDM ring is passed back to the main TDM controller for control and manipulation by the local sound model. Sounds and audio mixed and generated in the TDM controller can in turn be sent out in a digital format to the RIUs, which convert them back to analog audio signals.

This architecture allows the user to place the analog/digital interface close to an audio source such as a headset, reducing susceptibility to noise and crosstalk typically generated by long analog cable runs. The TDM ring allows for up to 14 RIUs driving up to 24 audio Input/Output channels. Multiple TDM rings can also be installed within a single DACS. This provides the user with a highly flexible and expandable architecture.

Interconnection: As with the Waveform Synthesizer, a high speed communication port connection is provided. This port provides the capability to link up to three TDM Controller cards together to form large communications networks.

Audio Processor Configuration

In general, any combination of Waveform Synthesizers and TDM Controllers can be installed in a 2U or 4U DACS. The number of audio processing cards or modules is limited to three, providing there are enough slots available in the chassis.

In a multiple Synthesizer/TDM Controller configuration, one card or module is configured as a master device. The remaining cards or modules must be configured as slaves. This configuration is important as sound model frame rate operation on the Model Processor is derived from the single master.

In systems with at least one TDM Controller, the TDM Controller will be configured as the Master.

Each Synthesizer/TDM Controller is also jumper configured for a specific address via a rotary switch accessed directly on the card. Addresses are from one to six and also correspond to the model number in the Model Builder software environment. Care should be taken when swapping or replacing modules to set the address appropriately. See your DACS engineering drawings for details on Synthesizer/TDM Controller jumper configurations.

Up to three audio processor cards or modules may be interconnected via the high speed communications port within a single DACS.

Remote Interface Units (RIUs)

As we saw earlier, Remote Interface Units (RIUs) are used in conjunction with TDM Controller cards to form a TDM based digital communications network.

Unlike most DACS hardware components, the RIU is a small unit located separate from the main DACS. RIUs are daisy chained together using standard category 5 UTP network cable to form a "TDM Ring". Both ends of the ring are connected to a TDM Controller card located in the main DACS.

Audio is sampled by the RIU and passed in digital format to the TDM Controller. Audio mixed and/or generated by the TDM Controller is also passed in digital format to the RIU.

The RIU provides both audio input/output capability and some limited digital I/O capability. In addition two serial ports are provided for connection of devices such as Hand Held Terminals and simulated or actual operator panels.

The RIU is a continually evolving product and multiple versions exist with varying specs and features. Care should be taken when ordering spares to include the full part number. Consult your engineering drawing set shipped with your equipment or examine the part number indicated on the RIU itself to determine which version you have. At the time of this writing, RIU version 4.1 is the current hardware version.

This manual is only concerned with the operation of version 4.1 and later RIUs.

All RIUs ship with a basic user guide which provides specifications, configuration information and other general information specific to the version of RIU shipped. Current and legacy RIU manuals may also be downloaded from the ASTi website:

<http://www.asti-usa.com/>

Audio Inputs: Audio input preamp gain can be configured from 0dB to 60dB via jumpers on the RIU circuit card. Factory setting is a gain of 40dB. Input voltage should not exceed 4.5Vp-p for a gain setting of 0. For other settings, voltage levels should not exceed 4.5Vp-p after the gain has been applied.

Phantom power capability is available on the RIU Version 4.1 and later. The phantom power capability is very limited, providing only 10VDC across the microphone lines.

See appendix A or consult the RIU user guide shipped with each RIU for additional interface and configuration information.

Audio Outputs: Version 4.1 and later RIUs have a 4.5Vp-p output drive capability into an 8Ω bridged load.

Digital I/O: A general purpose digital input and digital output is provided with each audio channel. The digital input is convenient for sensing PTT (Press-To-Talk) switch states directly. The digital output is convenient for driving PTT inputs on actual communications equipment or for driving small LEDs.

Serial Ports: Two serial ports are provided for direct connection of Hand Held Terminals, communication control panels, simulated radio panels, etc. Serial ports are active in version D RIUs and later only. Operation also requires the installation of Model Builder version 4.0 or higher.

The serial ports effectively act as an I/O interface for whatever panel or control unit is connected. Panel state information is read by the RIU and returned to the main DACS unit. This information is then typically passed on to a dynamic link library (DLL) for processing. The DLL, running a custom developed state machine model for the panel, processes the data and returns additional state parameters for use either by the sound and communications models or the panel itself.

Packaging and Layout: The RIU is generally provided in a standard enclosure. Unpackaged, circuit board only versions and custom enclosures can also be provided by special request. The standard packaged unit is approximately 5.5” wide x 1.5” high x 8.5” deep. See appendix B for a mechanical layout of the RIU standard enclosure.

Audio and digital I/O interface is via a set of female D sub 9 connectors located on one of the end plates. Individual channels are marked A-D. Located on the opposite end panel are two RJ-45 connectors for connection of the TDM link cable.

Two RJ-12 connectors are also located on the end panel for interface to the two serial ports.

A red power/error light and a green sync indicator light are also located on the end plate to provide status information.

A rack mount kit is available for mounting up to three RIUs in a 19 inch rack with 1U of rack space.

See Appendix A or consult your RIU documentation for additional specifications, configuration and interface information.

Status Lights: For proper RIU operation, the RIUs must be synchronized with the TDM Controller. In a standard TDM ring configuration, the TDM controller continuously sends out a sync signal to all RIUs on the link. The RIUs synchronize to this signal at start-up. Because of this, the RIUs must be connected to the TDM ring either at power up of the main DACS or prior to loading a model.

A solid, red LED indicates there are no sync pulses on the TDM ring. A flashing, red LED indicates the presence of sync pulses on the TDM ring, but the RIU cannot synchronize with the Model Builder software running on the DACS.

The green LED on the RIU indicates its sync status. The LED will flash at a 5 Hz rate while the RIU attempts to synch. When the RIU is synchronized, the LED will blink at a 1 Hz rate.

Audio Interface Unit

This device is no longer available as a production item, but supporting documentation can be obtained by calling ASTi at 703-471-2104 or sending email to:

`support@asti-usa.com`

Network Interface

Each DACS can be configured with up to two network interface cards. These cards provide access to other computers on local and wide area networks in support of the following functions:

- Interface to a Host Simulation computer to receive simulation state data for control of the local audio model(s)
- Interface directly to a DIS compatible network for simulation of radio communications and intercom between ASTi DACSs or other DIS compatible platforms

For systems with a single network card all network traffic is supported via this card. This includes transmission and reception of:

- Host computer simulation state data used to drive the local sound and communications model(s)
- DIS or HLA format Transmitter, Receiver, Signal, and Entity PDUs

Systems with two network interface cards provide greater flexibility in distributing the packet information described above. For this type of configuration, one card is designated as **“Host Interface”** and the other **“DIS Interface”**.

When two network interface cards are installed in the DACS, consult your engineering drawings or markings on the back of the equipment to determine which card is the **“Host Interface”** card and which card is the **“DIS Interface”** card.

At least one network interface card must be installed in the system for proper operation. Software options are keyed to the network interface card (the **“Host Interface”** card on systems with two) and will not run without the proper card installed. Network cards should not be swapped between

systems and spare cards also need to be properly keyed by ASTi. See the network card Remove and Replace procedures in chapter 5 for more information.

Network interface cards are PCI based 10/100MBs ethernet cards supporting 100baseT (Unshielded Twisted Pair) connection.

Ethernet operation conforms to IEEE 802.3. UDP level protocol with IP addressing is supported along with some multicast capabilities.

The following sections discuss the individual network interface features in more detail.

Host Simulation Interface: Simulation state and sound model control parameters generated by a simulation application on another network computer can be transmitted to the DACS via one of the DACS network interface cards.

Parameters include state data such as engine RPM, radio frequency, communications panel switch settings, radio position, exercise number, etc. These parameters are brought into the local audio models using special input control objects found in the modeling environment.

In addition to reception, model information and equipment health status can be also passed from the DACS back to another computer through the same link.

The DACS can receive information from up to eight individual computers on the network by specifying different UDP port numbers for data originating from the different machines.

Status and monitor screens are provided in the Model Builder runtime environment enabling the user to monitor network activity and examine data received or transmitted by the DACS.

Network configuration parameters such as port numbers, source and destination IP addresses, etc. are set by the user via command lines in the start up configuration file. Consult the Model Builder Reference Guide for more information.

DIS: When configured for DIS operation the DACS connects directly to the DIS network. Signal and Transmitter PDUs are transmitted and received directly, off-loading the host or other network interface device from dealing with these processor intensive PDUs.

Status and monitor screens are provided in the Model Builder runtime environment enabling the user to monitor network activity and DIS radio traffic.

DIS options, and network parameters are set via configuration commands in the start up configuration (default.cfg) file. Consult the Model Builder Reference Guide for more information.

Terrain Database/Application Interface

Systems with the Terrain software package enabled and Model Builder version 3.11 or higher have the ability to interrogate a terrain database server or other terrain application on another network computer for additional path loss information. For systems with two network cards, path loss requests and path loss information packets are transferred to and from the DACS via the Host Interface network card.

See the Model Builder Reference Guide or the Terrain Database Interface Application Note for further information.

Tactical Data Link Interface

Systems with Model Builder version 3.12 and higher have the ability to receive tactical data link information from another network computer for transmission over DIS or HLA networks in the form of Signal PDUs. Tactical data link information received by the DACS from the DIS or HLA network can also be returned to a network computer.

When using DIS, this operation requires a DACS with two network cards. Packets containing the raw data are transferred to and from the DACS via the Host Interface network card. When using HLA, this operation requires only a single ethernet interface.

See the Model Builder Reference Guide or the Tactical Data Link Operation Application Note for further information.

I/O Interface

The DACS supports the use of a digital input/output card. If using RIUs, a Distributed Digital Interface (DDI) may also be used.

These I/O cards and modules are useful for monitoring volume controls, press-to-talk switches and other controls directly by the DACS rather than through an I/O system connected to the host. The state of these inputs can also be passed back to the host through the host interface network card.

Digital Input/Output: The Digital Input/Output card/module provides 8 digital inputs and 8 digital outputs via a 37 pin, male, “D” connector. The digital inputs are voltage-sensing with external sourcing voltage of +5VDC. Connector pin out information and configuration information are shown on the engineering drawing included with the system. Consult the system drawing to determine the part number included with your system and then consult the Digital Input board drawing for configuration information. 3rd party vendor information is generally provided to assist the user in interfacing to the board correctly. An ASTi application note is also available to assist with interface to this board.

Distributed Digital Interface (DDI): This module connects directly to an RIU’s serial port. DDIs can support 32 digital inputs, 8 digital outputs, and 4 analog inputs. Up to 7 DDIs may be connected to each RIU serial port, maximum 14 DDIs per RIU. Reference ASTi’s “DDI Technical Guide” (ASSY-01-DDI-MN-1), available for download from the ASTi website, for more information.

DACS Software

Several software packages are installed on the DACS. These include the ASTi Model Builder sound model generation application software and DOS operating system software. The following sections describe the DACS software in more detail.

Model Builder Sound Model Generation Tool Kit

The ASTi Model Builder sound model generation software offers a structured, object-oriented approach to building a simulated audio environment. Through Model Builder’s menu and display system, sound models are constructed to meet your audio simulation requirements.

Models consist of different lists of high level sound, mixing, and control objects. Model Object Lists are comparable to an object database. Each object performs a specific function, e.g. generating a sine wave, simulating a radio, generating a noise source, connecting a host input control to an object parameter, or playing a prerecorded sound. Within each copy of a given object there is a series of parameters which control the operation of the object (e.g. frequency and amplitude control for a sine wave). These parameters are displayed dynamically on the DACS monitor, and can be modified as required in real time.

Where logical, a parameter or object output can be connected to the other objects in the model. This provides a general purpose mechanism for control of any parameter, from both within the model, or from the host computer. Parameter values and their connections are stored with the object's representation in the model.

Examples of objects available in Model Builder's object library include: Sine Wave, Filter, Pulse, Noise Source, Play Sound, Balancer, Propeller, Rotor, Radio, Jammer, Engine, Communication Panel, Input Float, Input Ascii, Record, and many more. For a complete list of available objects and their descriptions consult the Model Builder Reference Manual.

All audio signals produced by a sound model can be mixed in any combination to any output channel. Sounds are mixed onto what is called the Mixing Highway. The Mixing Highway is the digital signal path from your model(s) to your analog outputs. Signals placed on the various Mixing Highway channels are then connected to the required analog outputs using the desired mixing objects. Analog inputs are added to the Mixing Highway using special Input Objects. This allows external audio sources such as microphones to be input, mixed, and controlled as part of your sound model. Figure 3 shows a block diagram of a typical Model Builder application.

Figure 3: Typical Model Builder Application Block Diagram for a Combined Aural Cue and Communications Model

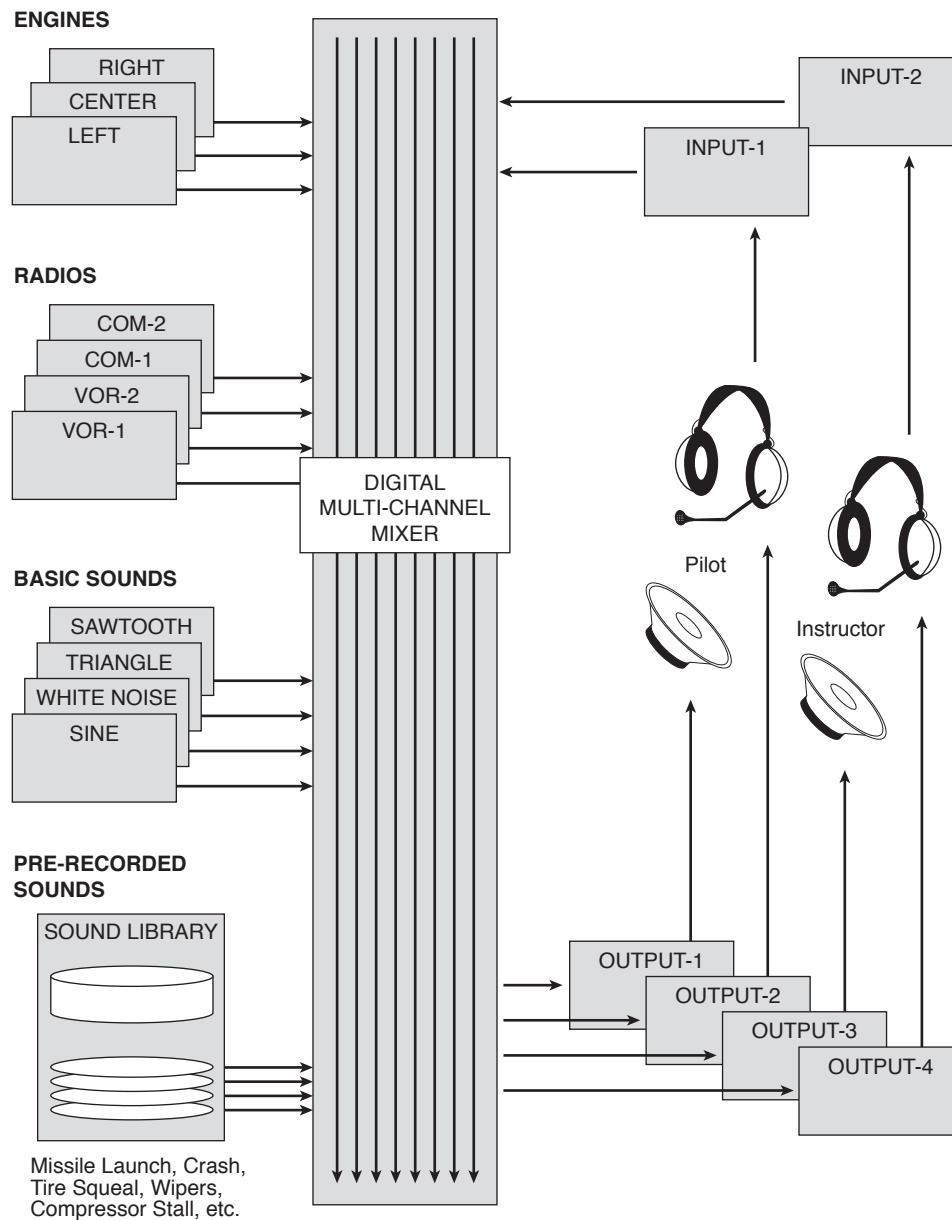

For an in depth understanding of the Model Builder software environment, see the Model Builder Reference Guide.

Software Key/Options

A software key floppy disk is provided with each DACS. The disk contains an options file which enables the software options or credits purchased by the user.

The options file is pre-installed prior to DACS delivery but may be reinstalled at any time. When installed, the disk places the options file (indicated by a .opt extension) in the \MBUILDER\BIN directory.

The options file is keyed to the system ethernet card (Host Interface on systems with two cards), so that an options file on one system will not work on any other system.

If it becomes necessary to replace the ethernet card, a new options file keyed for that specific ethernet card must also be installed. Ethernet spares shipped from ASTi include a new software key disk. It is important when ordering ethernet card spares to include the system serial number and physical card address. Without this information the proper options cannot be coded for the spare device. Each options disk lists the system serial numbers it supports on the rear of the disk.

Multiple options files may reside in the \MBUILDER\BIN. This allows the user to pre install options files keyed to the original ethernet card as well as any spare cards used to support the system. This will alleviate having to load the options file at the time the ethernet card is replaced. Model Builder reads all options files at start up, searching for a match with the current ethernet card.

Because the options file is keyed to the ethernet card, the system will not work without an ethernet card installed.

Operating System Software

The DACS operating system software will typically be Microsoft™ MS-DOS. In addition to normal operating system software functions, this software also provides useful utilities such as file editing, back up and restore capabilities, etc. which the user may find helpful. Vendor documentation and licensing information is supplied and should be consulted for additional information about operating system and support utility capabilities.

Support and Utilities Software

Support and operating system software packages may also be included with the DACS. All DACS configurations include DOS operating system software. Additional support software may be installed depending on the DACS configuration or upon special customer request. For example, systems with a tape backup unit will include tape backup software already integrated and ready to use.

Installation of 3rd party packages by the user is generally discouraged as ASTi can make no guarantees that user installed software will not affect the performance or operation of the DACS.

Custom Audio and Simulation Software

Customers who contract ASTi to develop custom audio models for their application will receive an additional set of installation disks containing the DACS audio models. These disks are typically delivered separate from the hardware and there may be several releases prior to conclusion of the contract.

Installation of the disks is the responsibility of the customer. See the Cold Start Procedures later in this manual for further information on installing custom models.

Those customers whose applications include an ASTi Model Server platform will also receive an installation disk containing the routing table configuration file.

Again, installation is the responsibility of the customer.

Software Licensing

ASTi's Model Builder software and optional packages are licensed on a per system basis. It is illegal to transfer this software to another platform or update to a later version of the software without expressed consent by ASTi.

Software may be pre-installed on spare systems for support purposes. The software may not be operational, however, unless the spare system has replaced another down unit. For further information consult the Software License agreement provided in the software section of your DACS documentation.

All other third party software including the DOS operating system are provided with the original vendor documentation and software license agreements. Consult this documentation for Licensing restrictions.

Chapter 3: Preparation for Use

This chapter provides the preparation and installation information needed for Digital Audio Communication System (DACS) operation. Topics covered include receiving, inspection, external equipment installation, and software set-up.

Receiving and Unpacking

Upon receipt of your ASTi Digital Audio Communication System, check that all containers have been received according to the shipping manifest and that no apparent damage has incurred during shipping. Do not accept containers that are obviously damaged without first consulting with the carrying authority.

Unpack and carefully remove the DACS components from their shipping containers in accordance with procedures common to industry standard practices. Be sure to observe all notes, caution or warning labels as may be apparent on the outside and inside of the shipping containers.

Parts Inventory

After all equipment has been removed from their containers, verify equipment and documentation received against the shipping invoice. Notify ASTi immediately of any discrepancy.

All Digital Audio Communication Systems are shipped with Engineering Drawings which identify the system configuration and card arrangement within the DACS. RIUs and AIUs are also packaged with additional configuration and user information. Packing lists also provide detailed information about the shipment and may contain important notes.

Verify that the system received matches the top assembly drawing to ensure that all components are installed and configured correctly. Notify ASTi of any discrepancy.

To determine that the appropriate Model Builder software packages have been provided, examine the Software Protection Key Code Disk included with the system. Software Packages (also called software options) which are installed on the system are listed on the disk label. Verification can also be made once the system is operational by examining the Model Builder Options page within the Model Builder software environment.

Note 1: Original copies of software can be found in the documentation book.

Note 2: When using a MicroDACS, the DOS installation software is provided on a separate CompactFlash™ module. This module is used when cold-starting the system.

System Installation

To prepare the DACS for operation, perform the following installation procedures:

- Mount main DACS unit in standard 19" rack or locate on shelf or desktop depending on the model.
- Select appropriate power and install power cable.
- Connect monitor and keyboard (if required).
- For systems with TDM Controllers configure each RIU as required for the application and physically install the RIU at the desired location.
- Connect all panels or devices to RIU serial ports if applicable.
- Cable each TDM ring.
- Connect power to each RIU. Power supplies are provided with each unit.
- Connect all external audio equipment such as amplifiers, ASTi Audio Interface Units (AIU), microphones, headsets, and I/O cabling to the DACS Waveform Synthesizer, RIUs or appropriate I/O cards.
- If a single network card is installed, connect the system to the appropriate network.
- If two network cards are installed determine the desired routing of specific data (see Network Interface section in Chapter 2) and attach the two interface cards to the appropriate network.
- Apply power to the DACS.
- Set up the system configuration file (typically, default.cfg) with the appropriate network and system start up parameters. Commands are detailed in the Model Builder Reference Guide.
- If the DACS is being used in conjunction with an ASTi Model Server Platform install the routing table command file.
- Install any sound and communications models and sound files developed by ASTi or the user.

These procedures are discussed in more detail in the following sections.

Physical Installation

2U and 4U Systems: 2U and 4U units are provided with rackmount ears which can be bolted directly to rails in a standard 19" rack. Mounting screws are not provided. Standard systems consume 2U of rack space and are approximately 18" deep. Cabling is connected to the rear of the unit. Floppy and removable drives are accessed from the front.

Systems with the Plus option are 4U in height and approximately 19" deep including handles on the front. Cabling is connected at the rear of the unit. Floppy and removable drives are accessed from the front.

It is recommended that users also install additional angle brackets in their rack for extra chassis support

See Appendix D for additional mechanical information.

MicroDACS (PC/104) Systems: These systems are rackmountable using a separately-purchased 2U-high rackmount bracket, but are small enough to fit on a shelf within a 19" rack. Cabling is connected at the rear of the unit. The removable media slot is accessed from the front.

Because the size and layout of this chassis are subject to change, contact ASTi for latest information.

Power Connection

2U and 4U Systems: For these systems, power cord attachment is in the back of the chassis. The power switch is in the front, and may be either a rocker switch or a push-button switch.

Before connecting power to the Digital Audio Communication System, ensure that the ON/OFF or push-button switch is in the OFF position.

Verify the Power Supply voltage selection switch is set to the appropriate voltage (110/220) for your location. Switch is located on the rear of the chassis near the power supply fan. Some systems may have autosensing power supplies, indicated by a label on the rear of the platform.

Note: The power cord supplied with DACS is designed for connection to a standard U.S. 60HZ/110VAC 3 wire outlet. If DACS operation is required overseas or in a 220 volt environment the user will need to provide the appropriate power cord for that environment.

Connect the power cord to the power connector in the rear of the DACS.

During normal operation, the DACS draws less than 4A @ 115VAC.

MicroDACS (PC/104) Systems: These systems use an external +5VDC power supply. Because of the threaded, locking power-supply connector, use only ASTi-furnished power supplies with a threaded collar.

Monitor Connection

For convenience, some 2U and/or 4U power supplies provide a power connection for the monitor on the rear of the chassis. This connection allows the monitor to be plugged directly into your DACS. Power cords to fit this connection can be purchased for your monitor from your local computer store or distributor. The monitor may also be connected to an independent power strip.

With the Monitor connected directly to the DACS, the DACS draw less than 5.5A @ 115VAC for most types of monitors.

After your monitor AC power cord is installed, connect the video cable to the 15 pin, sub-miniature "D" connector found on the rear of the DACS.

Keyboard Connection

On the 2U and 4U systems, the keyboard connection is either via a 5-pin DIN (AT-style) connector on the front of the DACS chassis, a 5-pin DIN (AT-style) connector on the rear of the DACS chassis, or via direct connection to the CPU board keyboard connector which is generally a 6-pin mini DIN (PS/2-style). The MicroDACS accommodates a standard USB keyboard. *Use of a PS/2-to-USB adapter is NOT recommended.*

On all systems, the DACS is configured to boot and operate properly with or without the keyboard connected.

TDM Ring and RIUs

Systems using Remote Interface Units (RIUs) will have one or more TDM Controller cards installed in the main DACS. Each TDM Controller is used to drive one digital TDM ring. RIUs are distributed around the ring, providing remote interface of headsets and other audio equipment. Multiple versions of RIUs exist, and care should be taken when ordering spares or follow-on systems, as different RIUs have different features and firmware versions. The version number is indicated in the part number (e.g., RIU-4-AA indicates a version 4.1 RIU with version X.X.X firmware).

RIU Installation and Configuration: Before installing RIUs, each unit on a TDM ring must be configured with a unique address. The address switch is accessible from the outside of the unit. Valid addresses are from 1-16 (1-F in hexadecimal).

If control panels or other serial devices will be connected to the RIUs consult any ASTi installation drawings or notes provided as the panels may need to be associated with a specific RIU address.

After the address is set the user may also need to configure the input gain. See the following section on audio equipment connection for further details.

Once the RIUs are configured they can be physically installed. Physical dimensions are provided in Appendix B. A configuration and installation guide is also provided with each RIU unit

The unit is approximately 1.5" x 5.5" x 8.5", small enough to be mounted in space limited areas. The unit can also be conveniently placed on a desktop. An optional 19" rackmount bracket is available which allows up to three RIUs to be mounted in 1U (1.75") of rack space. Note that no mounting brackets or hardware are supplied with the unit.

Control Panel and External Serial Device Connection: For those applications which require connection of a Hand Held Terminal, an operator control panel, simulated radio panel, or other serial device, no special hardware configuration is required.

Note that serial port connection is only available for legacy RIU versions D and up, and the DACS must be running Model Builder version 4.0 or later.

Prior to connection of the panel or device, the user should consult any installation drawings or notes provided by ASTi to ensure that panels are connected to the correct TDM ring, RIU, and Serial Port. Failure to do so may cause improper routing of cell data.

Devices are connected to one or both of the two available RIU serial ports. Ports are marked A and B. Interface is standard RS422. Connectors are standard RJ12. See also Appendix A for additional interface information.

TDM Ring Configuration: Once each of the RIUs are configured and mounted, the TDM ring itself can be constructed. This is accomplished by connecting standard category 5 UTP network cable between the TDM controller in the DACS and the first RIU on the ring. The next RIU is then connected to the previous RIU and so on until the last RIU is connected to both the previous RIU and the original TDM card, forming a ring which begins and ends with the TDM controller.

Both the TDM card and the RIU have two female RJ-45 connectors for connecting standard category 5 UTP network cable. Either connector can be used on the RIU and TDM card when installing the ring.

Repeat this procedure for each TDM card in the DACS.

Note that up to 14 RIUs can be placed on a ring, but only a maximum of 24 audio channels can be serviced. Other factors such as model complexity and DSP or CPU loading may further limit the actual number of audio channels serviceable by the ring. Refer to Application Note 30A on the ASTi website for additional information.

Power Connection: An external AC/DC converter is provided with each RIU. The converter plugs into a standard 120VAC outlet. Power required is 5VDC as noted on the RIU face plate.

Connect power to each RIU. The Red power LED should light briefly when power is applied.

Initialization: When the DACS powers up or when the Model Builder application software is booted, the RIUs will spend a few seconds synchronizing to the TDM card. The synchronization status is indicated by the green and red LEDs on the RIU. If the red LED is solid, there are no sync pulses on the TDM ring. If the red LED is flashing, sync pulses exist on the TDM, but the RIU cannot synchronize with the DACS' Model Builder software. During the synchronization process, the green LED will flash at a 5Hz rate. When the light begins blinking at 1 Hz, the RIU is synchronized and ready for operation. Lights on different RIUs may blink out of phase. This is normal.

When powering up the DACS the RIUs should be powered on at the same time or before the DACS itself to avoid synchronization problems. If a synchronization problem occurs use the restart feature located in the top level model builder menu or power the DACS off and then on.

Note that operation of communications panels or other devices connected to the RIUs will not be operational unless the Model Server Platform (if used in legacy installations) and network are also operational.

Audio and I/O Equipment Connection

External audio and I/O equipment such as headsets, microphones, amplifiers, preamplifiers, VCR audio in/out, tape players, PTT switches, wire line adapters, etc. are connected either directly to the DACS Waveform Synthesizers and RIUs or through various audio interface equipment.

For systems with Waveform Synthesizers, each card or module provides up to eight channels of analog audio inputs and outputs (eight inputs and eight outputs). Connection is made via a 37 pin, female "D" connector located on the module face plate. Connector pin-out is shown in Appendix A and on the Waveform Synthesizer Engineering Drawing supplied with the DACS.

For systems with RIUs, each RIU provides 4 channels of analog audio inputs and outputs. A digital input and digital output is also provided with each audio channel.

Connection is made via a series of 9 pin, female "D" connectors located on the RIU face plate with each connector providing one audio input, one audio output, one digital input, and one digital output. Connector pin-out is shown in Appendix A.

External amplifier, preamplifier, headset, microphone, or speaker connection is not required to run the Model Builder sound model generation software. Sound models can be developed and run without external equipment connection.

Audio Inputs

Both the Waveform Synthesizer and RIU analog inputs are high impedance (>10kOhms), full differential (balanced) inputs. The RIU inputs are capacitively coupled.

Maximum Waveform Synthesizer input voltage is 3Vp-p. Maximum RIU input voltage is 4.5Vp-p.

Line Level Device Connection: For most standard line level devices such as a tape player or VCR, the audio output of these devices can be connected directly to the Waveform Synthesizer input. Check the specs of the equipment, for the maximum output level of the equipment. Even if the maximum output level is higher than the RIU or Waveform Synthesizer maximum input voltage, the actual audio output signal may never reach this level. Some equipment provide output level adjustments which can be used to reduce the output signal level. External pads can also be used to reduced signal levels. In most cases this will not be required. The use of isolation transformers is recommended between the RIU and the line-level device.

Microphone Connection: In general there are four types of microphones which the user may encounter. These include dynamic, amplified dynamic, condenser, and electret microphones.

Dynamic Mics: Dynamic microphones typically require 40 - 60dB of gain to bring microphone signals to a suitable input level. When connecting directly to a Waveform Synthesizer the user will need to set the channel preamp gains. Each Waveform Synthesizer input provides a preamp stage with gain adjustment from 0 - 60dB allowing direct connection of the microphone to the DACS.

To set the preamp gain values, commands are inserted in the Model Builder start-up configuration file. Gains can also be set temporarily from within the Model Builder software runtime environment. Consult the Model Builder Reference guide for input gain setting command information.

RIUs have adjustable gains via jumper blocks on the RIU circuit card. Gains from 0dB to 60dB may be set by installing the appropriate jumper. See the RIU configuration procedure found in chapter 5 or the configuration information supplied with your RIU.

For long microphone cable runs (50 feet or more), a preamp may need to be installed close to the microphone to boost the mic signal early and maintain a good signal to noise ratio and help avoid cross talk problems. This often depends on the installation. Use of good shielded, twisted pair cabling, with proper grounding can extend the cable length.

Amplified Dynamic, Condenser, and Electret Mics: These microphone types require “phantom power”, which is a DC voltage level supplied on the microphone signal line. The current provided is used for microphone element operation, preamplifier power or both. Microphone signal levels for these microphones is typically much higher than that of dynamic mics. In some cases, little or no additional pre-amplification may be necessary.

Direct connection of these types of microphones to a Waveform Synthesizer input is not possible as the card does not provide a phantom power source. For DACS with Waveform Synthesizers only, the user will need to either provide the phantom power source, or install a commercially available mic preamplifier with appropriate phantom power. ASTi’s AIU may also be used to provide phantom power.

RIUs (version 4.1 and later) have a limited phantom power capability. Resistor packs are used to set the voltage level available to the microphone. The user may also use other commercially available phantom power adapters.

Audio Outputs

Waveform Synthesizer audio outputs are low impedance ($<100\Omega$), single ended (unbalanced) outputs. Maximum analog output levels are approximately 6Vp-p into 600Ω or larger loads.

RIU audio outputs are low impedance (0.1Ω into an 8Ω load), differential (balanced) outputs. Each channel is capable of supplying 1W RMS into a bridge-connected 8Ω load. If a single-ended 8Ω load is connected, the RIU will supply 250mW RMS.

Line Level Device Connection: As with the analog inputs, standard line level devices such as a tape player or VCR, the audio input of these devices can be connected directly to the Waveform Synthesizer output. Check the specs of the equipment, for the maximum input level allowed by the equipment. Remember that the actual audio output signal from the Waveform Synthesizer or RIU may never reach this level depending on gain levels set in both software and hardware. To be safe however, the user may wish to scale the output gains by setting scaling factors in their sound model itself. External pads can also be used to reduced signal levels. In many cases this will not be required.

Headset and Speaker Connection: Headset impedances vary widely from headset to headset. In general the Waveform Synthesizer and RIUs can drive a 600Ω headset directly, however, dynamic range may not be satisfactory. Headsets down to 150Ω or below can also be driven, but generally not to full scale.

As an example, most military headsets are very low impedance (typically $10 -20\Omega$) and require amplification. Users may also require headset amps if higher headset volume levels are desired. Some users may find that some of the commercially available $150-300\Omega$ headsets are adequate without amplification. ASTi offers a headset evaluation service to assist customers with their audio interfacing requirements.

Speaker channels will also require amplifiers between the audio output and the speaker. Good quality, commercial stereo amps are excellent for this application. Audio outputs can be hooked directly to most speaker amplifiers. To minimize ground loop problems, be sure to use balanced inputs or utilize the ground lift capability on your amplifier if available.

Audio Interface Unit

This device is no longer available as a production item, but supporting documentation can be obtained by calling ASTi at 703-471-2104 or sending email to:

`support@asti-usa.com`

Cabling

For minimum noise, individually shielded, twisted pair cable should be used for all audio lines. Shields should be tied at a single point to a good earth ground and in general should not be connected to audio ground.

Of utmost importance is using a shielded twisted pair on the microphone line. Microphone lines usually carry a very small signal and typically run next to the headset line which typically has a much larger, higher current signal. The potential for additional noise and crosstalk is greatly increased if proper cabling techniques are not used.

Network Interface Connection

Each DACS may contain one or two network interface cards. Network interface cards are PCI based 10/100Mbs Ethernet cards.

Cable connection is located on the rear of the DACS chassis. Attach your Ethernet network cable(s) to the RJ45 connector(s). Standard off-the-shelf network cabling can be used to make the connection. Be sure to use cabling recommended for 100Mbs (Fast) ethernet applications.

Systems with two cards may be configured to direct certain types of data to be transmitted and received via either the A or B network card. Be sure to determine your network layout and the type of information on each network before connection. Cards will be marked on the rear of the chassis and indicated on the Engineering drawings supplied with the system. See the section on Network Interface in Chapter 2 for more information.

Note: *Ethernet connection is not required to run the Model Builder sound model generation software. Sound models can be developed and run without network connection, Network card A, however, must remain installed in order to use the Model Builder sound model environment*

Software Installation and Configuration

The ASTi DACS is delivered with an operating system, Model Builder sound model generation software, Model Server routing configuration files, and in some rare cases, 3rd party software applications. All software is pre-installed on the Model Processor hard disk. No initial software installation is required, unless the system was purchased as a “cold” spare. “Hot” spare systems are delivered fully-configured.

The DACS is preconfigured to run the Model Builder software environment automatically upon power up or system reboot.

In most cases system and network configuration parameters will also need to be set using the start up configuration command file. See the back of the Model Builder Reference Guide for more information.

Disks are provided for all software to accommodate cold start of the system. The diskettes may be found with the documentation that was delivered with the system(s). For information on how to reinstall your DACS software and reset your CPU operating parameters in the event of a failure, see the Cold Start section in Chapter 5, Test and Maintenance.

Note that sound and communications models, system start-up configuration files and cell routing files are not pre-installed.

Customers who have contracted ASTi to develop models will receive these files on disks as part of their contract. It will be the responsibility of the customer to install these disks upon receipt.

For sound and communications models developed by the user, the user is responsible for installing and maintaining their own files.

Chapter 4: DACS Operation

This chapter discusses DACS operation. Topics include powering the system up and down, software operation, interfacing to a host computer, and external equipment operation.

Powering the DACS Up and Down

Use the following procedures when powering up and down the DACS.

Power Up Sequence

To power up the DACS, perform the following procedure:

- Ensure that there is no disk in the floppy drive.
- For systems using TDM rings and RIUs, the RIUs should be powered up before or at the same time as the DACS to avoid any possible synchronization problems with the TDM ring.
- Switch on the DACS using the ON/OFF rocker switch or push-button located on the front of the chassis.
- The Model Builder software environment will start automatically and display the Model Builder Main Menu shown in “Model Builder Main Menu” on page 35.
- Ensure that all externally connected equipment is powered up as required.

Figure 4: Model Builder Main Menu

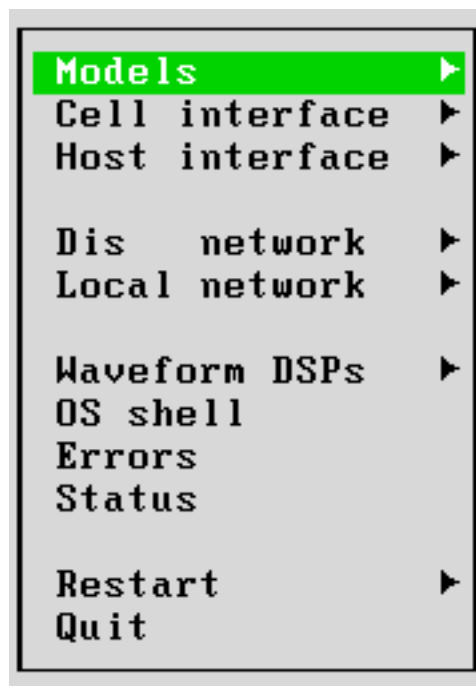

Power Down Sequence

To power down the DACS, perform the following procedure:

- Move to the Model Builder Main Menu by pressing [esc] from each lower menu or display.
- Select the 'Quit' option to exit the Model Builder environment and return to the DOS prompt.
- **Wait several seconds** while the DACS stores any recorded information still in cache memory to the hard disk.
- Switch off the DACS using the ON/OFF rocker or push-button switch located on the front of the chassis.
- Ensure that all externally connected equipment is powered down as required.

DACS Software

Software Structure

The DACS hard disk directory structure may vary from system to system depending on software revision levels and DACS configuration. A typical directory structure is shown below. This directory structure is formed during the DACS software installation process.

The directory structure is as follows:

```
\DOS
\TEMP
\BATCH
\MBUILDER
\MBUILDER\BIN
\MBUILDER\DEMO
\MBUILDER\DEMO\MODELS
\MBUILDER\DEMO\SOUNDS8
\MBUILDER\DEMO\SOUNDS16
\MBUILDER\DEMO\SOUNDS22
\MBUILDER\USER
\MBUILDER\USER\MODELS
\MBUILDER\USER\SOUNDS8
\MBUILDER\USER\SOUNDS16
\MBUILDER\USER\SOUNDS22
\MBUILDER\USER\RIU_TEST
```

The DOS directory contains the DOS operating system. The TEMP directory is created and used by DOS. The BATCH directory is used to store DRED routine batch files and is available for use by the user as well. Other directories may appear if other 3rd party software has been installed such as tape backup software.

The MBUILDER directory contains three subdirectories, BIN, USER, and DEMO. The BIN subdirectory contains the ASTi Model Builder application software files and the system software options file (identified by the **.opt** extension), and when a Model Server platform is used, it also contains cell routing configuration files (identified by the **.pth** extension).

The USER subdirectory provides subdirectories for model and sound file storage. This directory and associated subdirectories are intended for storage of your primary operational sound models and prerecorded sound files. The MODELS subdirectory is the default directory for your Model Builder sound models and Model Builder start up configuration file. The SOUNDS# subdirectories are provided for convenient storage of sound files. The # is a convenient way of indicating the sound file sample rates in Kilohertz.

The DEMO subdirectory is similar to the USER subdirectory but is intended for model and sound file development, and storage of example models and sound files supplied with the system.

The existing DACS directory structure should **NOT** be modified. Future software and custom sound model deliveries will assume this directory structure. Additional directories may be added, however, for model development, sound file storage, or to meet other user requirements.

Autoexec.bat and Config.sys

The *autoexec.bat* and *config.sys* files are located in the root directory of your DACS hard drive. These files are installed with Model Builder and provide the proper start up and operating conditions for the DACS. The *config.sys* file should only be modified when the DACS is going to interoperate with ASTi's Telestra Remote Management System (RMS) server. Refer to the RMS User Guide (DOC-XXX) for complete instructions and additional information. The *autoexec.bat* should not be altered, with the exception of the two command lines listed below:

```
CD \MBUILDER\DEMO\MODELS
MB
```

These two command lines are used to start the Model Builder software environment at boot up.

The directory specified in the first line indicates where the Model Builder application program will be booted from. This directory should contain the Model Builder sound models and Model Builder configuration file to be used when Model Builder boots automatically.

The second command line starts the Model Builder software. This line may be changed to specify a different Model Builder configuration file at boot up instead of the *default.cfg* file that Model Builder normally looks for. See the Model Builder User's Guide and additional information in this chapter.

CPU BIOS Configuration

The Model Processor CPU BIOS configuration is preset before shipment and should not be altered. Altering the BIOS set up can affect DACS performance. Follow the procedures listed in the Cold Start section in Chapter 5 exactly when performing a full cold start on the Digital Audio Communication System.

Model Builder Software

The ASTi Model Builder software is used to create, test and run sound models on the Digital Audio Communication System. Model Builder is both a platform for developing models and for executing them. The model can be executed during development and changed in real time. No compilation of any kind is necessary.

During normal operation, the ASTi Model Builder software is configured to start at system boot up. At start up, the Model Builder main menu is displayed.

Figure 5: Model Builder Main Menu

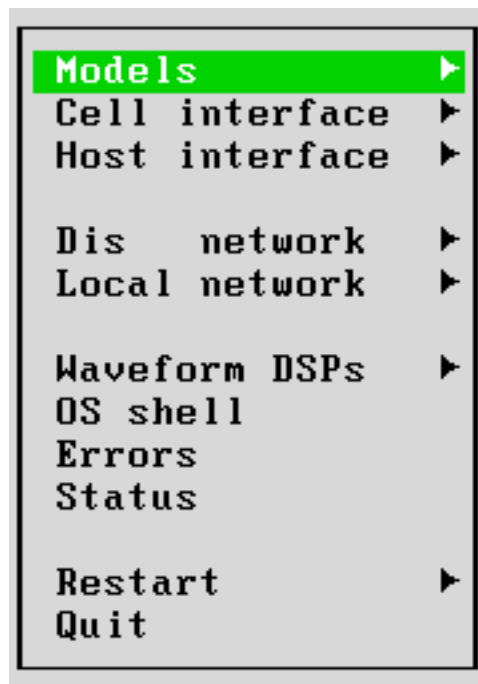

To quit Model Builder from the main menu, cursor to the ‘Quit’ option and press [return]. To reach the main menu from other Model Builder menus or displays use [esc] to escape out of each successive menu and display until reaching the main menu.

Model Builder provides you with the flexibility to specify various system parameters at start-up through the Model Builder Configuration File. The Configuration File is an ASCII text file containing configuration commands which set internal Model Builder operating parameters. The default name for the file is *default.cfg*.

The Configuration File is used to specify such items as:

- The name and location of models loaded at start-up
- The default directory path where your sound files are located
- Network configuration parameters (Host, DIS, and Terrain)
- Preamplifier gain settings (if Waveform Synthesizers are being used)
- System Frame Rate

For systems which are incorporating control devices attached to RIUs, a cell routing configuration file will also be required. This file contains routing information for data sent to and from RIUs, audio models, and the state machine (DLL) located on the DACS.

This file will typically be delivered by ASTi as part of custom panel, and simulation development. The default name for the cell routing configuration file is *default.pth*, and it is typically located in the C:\mbuilder\user\models\ directory.

Consult the Model Builder Reference Guide section for a complete description of the system configuration commands and features.

At start-up, Model Builder looks for *default.cfg* in the current directory. If the file is not found, Model Builder runs but uses fail safe settings for each command line feature.

Model Builder also looks for *default.pth* in the c:\mbuilder\bin directory. If the file is not found, no cell routing will take place. If the file is not present, and no cell routing is necessary, then there will be no negative effects on system operation.

You can modify a configuration file using the DOS text editor or any ASCII text editor you wish. You may also use a different file name for the Configuration File. To use a different Configuration File name, enter the file name after the **MB** command when you start Model Builder. The format is shown below:

```
C:\MBUILDER\USER\MODELS --> MB <filename>
```

Note that all configuration files require the **.cfg** extension. When specifying the Configuration File name with the **MB** command, however, you do not need to add the **.cfg** extension to the file name.

This feature is useful for creating different start-up configurations during testing. You can also add the file name specification to the **MB** command in your *autoexec.bat* file. Remember, you must start Model Builder from the directory containing the Configuration File for Model Builder to read your Configuration File parameters. Changes to your *autoexec.bat* file will only take effect upon restart.

Additional Software

Support software installed on the DACS includes the DOS operating system and in some cases additional support software such as tape backup. DOS provides the Model Processor with a standard PC DOS environment as well as extra utilities such as an editor for file modification. Vendor documentation for all installed packages are included with the DACS.

Model Generation and Operation Overview

The following sections provide a general operational overview of the DACS.

Overview Of Hardware and Software Functions

The Model Builder software is both a development platform for developing models and what actually runs the model. A model can be run as it is being entered, and changes can be seen (or heard!) immediately. It is not necessary to compile models. Models are saved as files with an **.mdl** extension.

There is one model running for each DSP card. The models *run* on the CPU, but they *control* the DSP cards. (A DSP card is either a Waveform Synthesizer or TDM controller.) Each model directs its DSP card to manipulate the sound it receives from the analog inputs, what sounds to generate, and what sound to send to the analog outputs.

Sounds can be shared between DSP cards (and models) through a 40 wire ribbon cable which connects the DSP cards together. Sharing sounds between DSPs requires that the models for those DSPs be coordinated with each other.

Some sound sharing can be done nearly automatically. For example, intercom busses can be set up across DSP cards to act as one bus. Simulated radio communications can also automatically send sound from one DSP to the other. (For details on sharing sound across DSPs, see the section on “Global Channels” in the Model Builder Reference Guide.)

Model Builder is designed with high level simulations of radios and intercoms. To the person making the model, they will see a “Radio” object, and will specify the frequency, world position, transmission power, etc. of the sender and the receiver. The Model Builder software will then determine if the receiver can hear the sender, and the signal-to-noise ratio. It will then route the audio from the sender, with the appropriate amount of noise mixed in, to the receiver. In this case, the CPU determines where the sound goes, the DSP routes the sound and mixes in noise based on the CPU’s instructions. The user, however, just sees a “Radio” object.

Objects

Models are made by entering the Model Builder software. This happens at start-up. Alternatively, from DOS, you can type MB. After a few seconds, the Main Menu will appear. (Menus may vary due to software configuration.)



Move the Cursor to Models and press ENTER. The “Models” menu will appear:

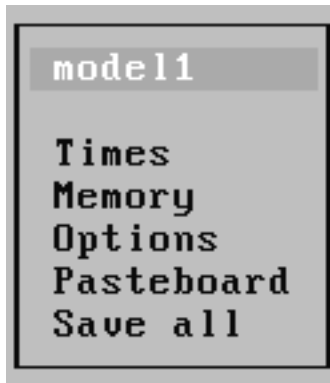

One model will appear for each DSP. “model1” is the model controlling the first DSP, “model2” is the model controlling the second, etc.

Moving the cursor to one of the model entries and pressing ENTER will produce the Model Configuration window. Pressing F2 will produce the following menu, which allows you to put objects into your model.



A model consists of “objects” which are tied together. Objects are divided into three major types: Controls, Signals, and Feeders.

Control objects produce numbers or on/off logic that is used to manipulate other parts of the model. Control objects include, counters (which gives an incrementing number), functions, lookup tables, morse code generators, and other objects. In addition, control data sent to and from a host simulation application, to and from control panels or to and from a state machine go through control objects.

Signal objects produce sound. They range from simple objects, such as sine waves, to sophisticated objects, like intercom busses and radios. They all generate or process sound in some way. In addition, the sound from the analog inputs is brought in through a signal object. Recorded sounds that are played back are also brought in through a signal object (called Play Sound).

Feeder objects send sound to the “output highways”, which drive the analog outputs. They include balancers, buffers, stereo pan, RIU in/out, and RIU 3-D audio out objects.

As an example, consider an application in which you want to play back one of eight recorded sounds under the control of a host computer.

The host computer sends ethernet packets to the DACS containing an integer. The model would consist of:

A control object, “Input Integer”, which would extract the integer from the received packet.

A Signal object, “Play Sound”, which is tied to a list of indexed sounds. The Control object is tied to the signal object, which uses the integer as an index value to pick one of a list of recorded sounds.

The signal object would be tied to a Feeder object, “Buffer”, which would direct the sound to one of the analog outputs. The sound would then be played on the specified analog output (or outputs).

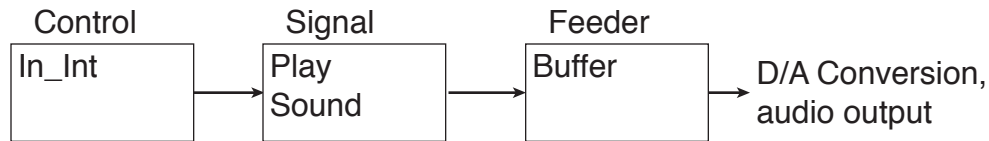

To add an object to the model, go to either Signal, Controls, or Feeders from the menu shown above. You will come to a list of the objects in the current model. If you have just started, the list will be empty. Press “Insert” to get a list of the objects you can insert. Move the cursor to one of the objects, and press ENTER. This will put one of the objects on the screen.

The objects and the object screens are described in great detail in the Model Builder Reference manual. There are some common details.

Parts that appear in blue type can be changed by the user. Things in yellow cannot, as they denote results. A series of dashes indicates where another object can be tied in. To tie in another object, go to the dashed line and press ENTER. This will give you the list of objects you can tie in. To select an object, move the cursor onto it and press the TAB key. (Not the ENTER key!)

To see an example of a basic model, exit out of Model Builder to DOS and type DRED_LOC. This will load the daily readiness test model, described in chapter 5.

Audio Processing (DSP) Hardware

As mentioned previously, models run on the CPU, but they control the sound processing of the DSP, with one model running simultaneously for each DSP.

The two types of DSPs are Waveform Synthesizers and TDM Controllers. They process sound in exactly the same way. The difference between them is how they get sound onto and off of the card.

The Waveform synthesizer has 8 analog inputs, with analog amplifiers and A/D converters. It also has 8 analog outputs which are driven by D/A converters.

The TDM controller also has no analog inputs or outputs. Instead, it sends and receives audio signals in digital form over a digital serial link called a TDM (for Time Division Multiplexed) link. This link attaches to one or more RIUs (Remote Interface Units). The RIUs pick up the digital sound and convert it to analog. It also takes in analog sound, converts it to digital, and sends it back on the TDM link back to the TDM controller. The TDM continues to do all the DSP functions of the other cards. For a diagram of this, see Chapter 2, “Hardware Overview”, in the sections about RIUs and TDM controllers.

Processor Loading

There are two types of processors in an ASTi DACS - the model processor, which has a Pentium or other X86 microprocessor, and the DSP processors. There is one DSP processor on each DSP card.

Both the Model Processor (or CPU) and the DSP processors can only handle a certain amount of information before they can no longer keep up with the simulation. Different tasks load these processors in varying amounts. Some tasks consume a lot of DSP processing, but very little CPU processing. Conversely, some tasks eat up CPU processing while using very little DSP time.

The following table lists the relative loading effects of various objects on the DSP and model processors.

Table 1: Processing Loads of Different Objects

Object	CPU Loading	DSP Loading
Mixer Object	Low	High
Radio Object	High	Medium
Comm Select Panel	High	Medium
Control Objects	Medium	None
Recorded Sounds	High	Medium
Intercom Bus	Low	High

In general, objects that mix large numbers of sounds (like mixers and Comm Select Panels) use a lot of DSP processing, while objects that require a lot of modeling (such as computing radio ranging effects) use a lot of CPU processing.

Generating signals (such as tones and aural cue sounds) uses DSP time, as does filtering sounds. Increasing sound fidelity by increasing the sound sampling rate also loads the DSP, by giving it more samples to generate and manipulate in the same amount of time.

Anything that forces the CPU to handle sound directly (recording and playing sounds, and DIS), uses up a lot of CPU time.

Network Interface

Host Simulation Interface

In order to manipulate or drive the sound and communications models developed on the DACS, a host simulation computer will normally provide simulation state and sound model control parameters such as engine RPM, radio frequency, radio position, communications panel switch settings, etc.

This data is transmitted over an ethernet network to the DACS and received via the Host Interface network card. For systems with two network cards, the Host Interface card will be marked to avoid confusion.

Communications with the DACS are asynchronous. The host computer transmits packets at the host defined iteration rate. The DACS Ethernet hardware receives and buffers the packet in local memory. With each DACS model iteration, the Model Builder application software uses the latest receive packet for host input data.

Some model state data and system health parameters can also be transmitted back to the host. Packet transmission for data being returned to the Host can take place each model iteration or be reduced in frequency via system start up parameters.

Data received is buffered and “brought in” to the model using various Control objects available in the Model Builder development environment.

The user can inspect and modify packet data as well as network modes and parameters through both on screen displays and also through the start up configuration file.

For transferring simulation state parameters, the DACS supports IEEE 802.3 standard UDP level protocol with IP addressing.

The use of UDP facilitates the reception of state data from multiple simulation sources by selection of independent port numbers.

The user will need to configure the DACS with the appropriate network settings to ensure proper network operation. See the Model Builder Reference Guide section called “Ethernet Configuration Commands” for complete Configuration File command line information.

DIS Interface

DIS (Distributed Interactive Simulation) is a simulation protocol standard developed jointly by industry and the military to enable interoperation of simulation and training devices over local and wide area networks.

One of the more difficult and often underestimated aspects of simulation over local and wide area networks is achieving a realistic radio communication environment.

With the DACS DIS option active the local radio and intercom modeling performed by the DACS is extended over the local and wide area network. Communication simulation between multiple DIS compatible network devices is invisible to the user with full radio modeling across systems.

All released versions of the DIS standard are supported and can be user selected.

During DIS operation, the DACS transmits and receives DIS standard PDUs. Since the DACS is involved strictly with communications simulation it transmits and receives Transmitter, Signal and Receiver PDUs only.

In addition, to accommodate entity attach features whereby a radio modeled on the DACS is attached to an entity on the network, Entity State PDUs are also received.

Chapter 5: Test and Maintenance

MTBF and MTTR

Mean Time Between Failure numbers for all DACS modules are included in Appendix B. When spares support is at the recommended module level, DACS Mean Time To Repair is less than 45 minutes for 2U and 4U chassis.

**** WARNING ****

Removing the cover of the chassis, as is required for hardware replacement procedures described in this section, will void any warranties on the system. If your system is still under a hardware warranty or you are unsure whether the system is under warranty, please contact ASTi in the event of a failure.

Tools and Test Equipment

No special tools or test equipment are required for testing and maintaining the DACS. The following items, however, are useful or required for some of the procedures found in this manual.

- 1/4" Flat Screwdriver
- #1 Philips Screwdriver
- Standard Needle Nose Pliers

Spare Equipment

The following sections provide information concerning sparing of equipment.

Spares Philosophy

In general the DACS maintenance philosophy is to isolate faults down to the lowest replaceable unit, remove and replace the faulty unit, and return the unit to the factory for repair.

Sparing should be implemented in one of two ways. Either by sparing the individual replaceable units or by purchasing a "Hot" spare configured identically at the system level which allows the entire DACS unit to be replaced quickly.

Spares Recommendations

To ensure the absolute minimum down time in the event of a failure, a “hot” spare unit is recommended. This spares the DACS at the system level and eliminates any need for technicians to enter the system to replace individual components.

Hot spare units consist of the same components contained in the system(s) they are sparing. Software is not included, thereby reducing the cost of the platform significantly. Often, the Hot spare unit contains all of the components a user would normally spare individually.

The user may preconfigure the spare unit with the correct Model Builder software version and any sound model and files for their application.

Where the “Hot” spare approach is cost prohibitive, one of each type of replaceable component in the DACS should be spared. To ensure compatibility with the rest of the system, all spares should be purchased from ASTi. Malfunctioning may result if the wrong type of hardware is installed.

Other reasons for buying spares at the time of initial purchase include:

- reducing cost and delivery time of repairs (unit availability can be as much as 90 days)
- costs for spare unit installation versus standard repair costs are often much less

In general individual spare components required will consist of the following:

- One Model Processor - this consists of the PC chassis, power supply, all disk drives (hard and floppy), CPU board, and backplane.
- One Host Interface Card
- One or more Waveform Synthesizer Cards

Systems which contain a removable drive module will want to spare the following:

- One Removable Hard Drive Cartridge with Hard Drive

Systems which contain TDM cards will want to spare the following:

- One or more TDM cards
- One or more RIUs.

MicroDACS systems will want to spare one or more of the following:

- CompactFlash™ or Microdrive™ removable media modules

Care should also be taken in sparing RIUs. Because different versions exist, the user should ensure that the full part number is verified and then specified when ordering.

If you are unsure of your spare requirements, please contact ASTi at (703)471-2104.

Preventative Maintenance

Very little preventative maintenance is required for the DACS. The following sections provide preventative maintenance information.

Filter Cleaning

Once each month (or more often if dust build up occurs) inspect the fan filters for excessive dust and dirt. Filters should be kept clean to help prevent heat buildup within the DACS.

- To clean the filters:
- Power down the DACS.
- Remove all fan covers.
- Remove foam filters and wash with a mild detergent and rinse. (In some cases vacuuming the filter may also be sufficient.)

Thoroughly dry and replace filters.

Software Backup

As with any computer system, it is recommended that you back up your DACS Model Processor hard disk on a regular basis. Your DOS operating system provides a convenient backup utility for backing up files. Consult the DOS documentation supplied with the system for more information. Commercial backup utilities can also be purchased for use with the DACS.

If the size of your backup becomes large, such as in the case where large record/replay files are created, it is recommended that a commercial tape back up system be used to back up your Model Processor hard disk.

Consumables

ASTi equipment uses no consumables.

Troubleshooting

The following sections provide troubleshooting guide lines in the event of a problem with the DACS.

Self Test Features

Daily Readiness Test (DRED) for Audio I/O: Your Digital Audio System is supplied with three automated Daily Readiness (DRED) test routines, Local, Host and RIU. The Local readiness test checks operation of the system by generating preset sounds through the DACS outputs without Host communication. The Host readiness test generates preset sounds through the DACS outputs but requires information to be transmitted from your Host computer. The RIU readiness test is similar to the Local readiness test but is used on systems with TDM and RIU components.

Each of the test routines are run directly from the DACS. The Model Builder models used in these tests can, however, be used as examples for generation of your own DRED test capabilities either within your real-time audio simulation models or as your own off line readiness test.

Incorporation of DRED test capabilities into your real-time models allows you the added advantage of initiating DRED testing through Host control. In addition, you can modify the DRED features in your simulation models to meet your particular needs.

The Daily Readiness Test support software comes already installed on your DACS. This support software is included on the Digital Audio System Utilities Disk supplied with your DACS and can be reinstalled during Cold Start procedures. The test software includes the following:

- Three batch files, *dred_loc.bat*, *dred_riu.bat* and *dred_hos.bat*, installed in the **C:\BATCH** directory on your DACS hard drive. These batch files are used to run the local and host DRED tests directly from the DACS. *Dred_riu* is the local daily readiness tests for systems with RIUs, while *dred_loc* is the daily readiness test for systems with 8 channel waveform synthesizers.
- Three Model Builder configuration files, *dredloc.cfg*, *dredriu.cfg* and *dredhos.cfg*, installed in the **C:\MBUILDER\DEMO\MODELS** directory. These configuration files include the Model Builder start up parameters for each test. See your Model Builder User's Guide and Model Builder Reference Guide for more information on Model Builder configuration files.
- Model Builder audio simulation model files are denoted by the **.mdl** extension and installed in the **C:\MBUILDER\DEMO\MODELS** directory. Three models are supplied for each Waveform Synthesizer or TDM Controller card in your DACS. One model is used for Local DRED test, another for the RIU local DRED test, and a third for the Host DRED test.

The tests described here are for systems with an 8 channel waveform synthesizer. The DRED_RIU test is described in a text file which is displayed when you run the test.

During both Local and Host DRED tests, each Waveform Synthesizer output generates a different type of sound. Table 1 describes the type of sound heard on each Waveform Synthesizer output channel. If the Waveform Synthesizer has only two output channels, the first two sounds listed in the table will be generated.

Table 2: DRED Test Sounds

Channel 1	Caution Tone
Channel 2	Recorded Engine Sound replayed from disk
Channel 3	Sine Wave Sweep
Channel 4	IFF Tone
Channel 5	Jamming Effects
Channel 6	Stall Warning Tone
Channel 7	ATIS Message
Channel 8	Missile Warning Tone

In addition, each input channel is connected directly to its corresponding output channel to facilitate communications testing.

If multiple cards are installed in the system, each card will replicate the above sounds.

Running Local DRED: Before running the Local DRED test you will need to have amplifiers and headsets or speakers connected to your Waveform Synthesizers in order to hear the test sounds.

To run the Local DRED test, quit from Model Builder. At the DOS prompt, make sure you are in the “c:\mbuilder\user\models” directory and:

Type: `dred_loc`

Press: [return]

The Model Builder environment will boot up and load the DRED audio models. Sounds should emanate from each output channel after the system has booted.

Running RIU DRED (For Host Interface): *** Need this information ***

Running Host DRED (For Host Interface): Before running the Host DRED test you may first need to change the ethernet addresses and input data format type listed in the *dredhos.cfg* file located in the **C:\MBUILDER\DEMOMODELS** directory. Use the DOS editor provided with your operating software to edit the file. Editor commands and descriptions are provided in the DOS vendor documentation supplied with your system. Consult your Model Builder User’s Guide or Model Builder Reference Guide for information on the configuration file and configuration file command lines.

Before running the Host DRED test you will also need to have amplifiers and headsets or speakers connected to your Waveform Synthesizers in order to hear the test sounds. You will also need to connect your Host Ethernet link to the DACS.

Table 3 below lists the packet byte location, data format, and data values that must be sent from the Host for proper test sound generation.

Table 3: Host DRED ICD

Byte Offset	Type	Value
0	1 Byte	0x01
4	32-bit Integer	8
8	32-bit Float	2.0
12	1 Byte	0x00

Test sounds can be turned off by setting byte 12 to 0x01.

If sounds are not heard, consult the Model Builder Ethernet Status Page (see the Model Builder Reference Manual for more information) to determine if packets are being received from the Host correctly. Also check the Rx Buffer Page (see the Model Builder Reference Manual for more information) to determine if the data listed in Table 2 is in the correct location and correct order.

Diagnostic Tools in the Model Builder Software

The Model Builder software has several display screens which indicate the state of the system. These screens can be useful for troubleshooting. For an in depth explanation of the screens, see the Model Builder reference manual. The following explanations are intended for the use of troubleshooters.

Model Builder DSP Timing Window: From the main menu, go to “Waveform DSPs”. Then go to “Times”. The following screen should pop up:

Figure 6: DSP TIMING WINDOW

```

- DSP Times / Memory Window
DSP Execution Counts
DSP Frame   Overrun

 1  D41E

DSP Execution Times
DSP Frame (us) Spare (us) %   Instn
 1  125.0000  123.3724  98.6  38378          Timer=35:36
- Esc-exit  PgUp/PgDn-page 1of3

```

This screen shows the activity of all the waveform synthesizers, TDM cards, and waveform accelerators. The list of DSPs will contain one entry for each such card in the system.

If there is a blank line in the middle of the list, the rotary switch setting on the corresponding card may be incorrect.

The Master Timer should be incrementing. If not, the jumper settings of the one or more of the DSP cards may be wrong. One of the cards should be jumpered as a “Master,” and the rest should be “Slaves.” If there is no master or more than one master, this timer will not be incrementing and the system will not work. Additionally, poor contact quality between the card and backplane could inhibit proper operation.

The Frame Counter should be incrementing for each card listed. If it is not, there may be a problem with the card, or the jumper settings may be incorrect. The frame counter will also stop if an attempt is made to load a model which doesn’t exist or has an error in the file. To start it up again, either load an existing model or clear the model using the “New” entry in the Model Configuration Menu.

The Overrun counter should be zero or blank. If a very large model is being run, and this counter is incrementing, then the card cannot keep up with the processing demands put on it, and the sound may not come out correctly.

If Global Channels are being used (see the reference manual for an explanation of global channels), the Com OK counter should be incrementing and the ComFail Counter should be zero. If the ComFail is not zero, the ribbon cable connecting the cards may not be installed properly, or may be loose or damaged.

If global channels are not being used, the Com OK counter will not be shown.

Model Builder Model Timing Window: The model builder Model Timing Window indicates the status of the model processor. To get to the window go from the Main Menu to the “Models” Menu, and then to the “Times” menu. For a complete description of the model timing window, see the reference manual.

Figure 7: MODEL TIMING WINDOW

Model	Execution Times (ms)								Main	Dsp	Disk	
1	Full	Run	Run	Run	Run	Run	Run	Run	Run	Run	Run	Run
Frame No	1	2	3	4	5	6	7	8	Peak	Average		
Model												
DSP	0.4	0.4	0.4	0.4	0.4	0.4	0.4	0.4	0.48	0.46		
Network	1.1	1.1	1.1	1.1	1.2	1.2	1.2	1.2	1.23	1.19		
Cell	0.8	0.8	0.8	0.8	0.9	0.9	0.9	0.9	0.94	0.83		
Total ms	2.4	2.4	2.5	2.4	2.6	2.6	2.6	2.6	2.67	2.51		
% Used	24	24	25	24	26	26	26	26	26	25		
Master Frame Count: 82CF					OverRun:							

The System Run State indicates whether the Models are running or frozen. If the system is frozen, no sound will be generated. The Model can be frozen and unfrozen by pressing the F3 key.

The Individual Model Run States should be set to run. If any are set to freeze, the corresponding DSP card will not produce any sound.

The Master Frame Counter should also be incrementing. If not, check the DSP timing window for a better idea of what the problem might be.

If most of the numbers are missing, the Waveform Synthesizer cards may be jumpered wrong.

The OverRun Counter should be zero. If a large model is running, and the OverRun counter is incrementing, it means the Model Processor can't keep up with the model, and the model may not be acting correctly. To compensate for this, model rate can be reduced. See the section on the Model Timing Window in the Reference Manual.

Ethernet Status Page: The Ethernet Status page indicates the status of the link between the host computer and the DACS. To get to the Ethernet Status page, go to “Host Interface” in the Main Menu, and then go to “Ethernet Status”. If only the word “Status” appears in the host interface menu, and this page says “KEY INVALID OR NO HOST INTERFACE PRESENT” then either there is no ethernet card, or the options file is not valid.

Note: The options file is preset at the factory, and cannot be changed by the user. If you have problems with your options file, please contact ASTi.

Figure 8: ETHERNET STATUS PAGES

```

Ethernet Status Window
Ethernet State : Run Protocol:IP only
Local Address IP: 192.168.100.104 @00-40-05-A1-EC-84
Subnet Mask IP: 255.255.255.0 Filter:Own+Broadcast+Multicast
TX Destination IP: 192.168.100.1 @00-00-00-00-00-00 Fixed_Address
TX Gateway IP: 0.0.0.0

UDP packets tx: 0000 rx: 0000.0000 RAW packets tx: 0000 rx: 0000
ICMP packets rx: 0000 tx: 0000 IGMP packets tx: 0000 rx: 0000
ARP reply rx: 0000 tx: 0000 ARP request tx: 0378 rx: 0000

RX Byte Count : 10515 TX Byte Count : 53280
RX Good Count : 00000074 TX Good Count : 00000378
RX Errors : 00000000 TX Errors : 00000000
Ethernet Valid : 1 DEC_2114x 21140 00-40-05-A1-EC-84 p:DC80
Esc-exit PgUp/PgDn-page 1of3

```

```

Ethernet Status Window
Ethernet State : Run Protocol:IP only
Local Address IP: 192.168.100.104 @00-40-05-A1-EC-84
Subnet Mask IP: 255.255.255.0 Filter:Own+Broadcast+Multicast
TX Destination IP: 192.168.100.1 @00-00-00-00-00-00 Fixed_Address
TX Gateway IP: 0.0.0.0

UDP packets tx: 0000 rx: 0000.0000 RAW packets tx: 0000 rx: 0000
ICMP packets rx: 0000 tx: 0000 IGMP packets tx: 0000 rx: 0000
ARP reply rx: 0000 tx: 0000 ARP request tx: 039A rx: 0000

RX MII Errors : 0000 TX Collisions : 0000
RX CRC Errors : 0000 TX Late Collision: 0000
RX Size Error : 0000
Ethernet Valid : 1 DEC_2114x 21140 00-40-05-A1-EC-84 p:DC80
Esc-exit PgUp/PgDn-page 2of3

```

```

Ethernet Status Window
Ethernet State : Run Protocol:IP only
Local Address IP: 192.168.100.104 @00-40-05-A1-EC-84
Subnet Mask IP: 255.255.255.0 Filter:Own+Broadcast+Multicast
TX Destination IP: 192.168.100.1 @00-00-00-00-00-00 Fixed_Address
TX Gateway IP: 0.0.0.0

UDP packets tx: 0000 rx: 0000.0000 RAW packets tx: 0000 rx: 0000
ICMP packets rx: 0000 tx: 0000 IGMP packets tx: 0000 rx: 0000
ARP reply rx: 0000 tx: 0000 ARP request tx: 03BB rx: 0000

Ring Overflow rx: 0000 tx: 0000 FIFO Errors rx: 0000 tx: 0000

Ethernet Valid : 1 DEC_2114x 21140 00-40-05-A1-EC-84 p:DC80
Esc-exit PgUp/PgDn-page 3of3

```

Typically, the UDP/IP protocol is used to for the Host Interface.

The Local Address is the IP address of the DACS (for host communications). The TX Destination is the IP address of the Host Computer. These numbers should agree with the addresses on the host computer.

UDP Packets rx (received) and tx (transmitted) is the number of packets received and sent to the host computer. If the rx number is incrementing, it means the DACS is receiving packets from the host. If the tx number is incrementing, it means the DACS is sending packets back to the host.

RX Good Count and RX Errors indicate the number of good and bad packets received from the host. If the RX good count is not incrementing, either the host is not sending packets to the DACS (or it's sending them to the wrong address), or the network is not connected.

The ARP request tx is incremented when the DACS goes out and looks for the host computer. If it finds it (that is, the host computer responds to the query), it will increment this only occasionally. If not, the DACS will continue to interrogate the network and this counter will increment about once a second. If the host computer replies, the ARP reply rx will increment.

The ARP request rx is incremented when the host computer looks for the DACS. The DACS should respond, and increment the ARP Reply Tx counter. When operating correctly, these counters will increment very slowly.

Errors Page: The Errors Page is on the Main Menu. If any errors or warnings occur, an error (or warning) message is printed here as well as displayed at the bottom of the screen.

Isolating Hardware Failures

The following procedure should be used to isolate suspected hardware faults down to the module level.

To check the status word, go to the Host Interface Menu, and then the Ethernet Control window. The status byte is towards the bottom of the page after the word "Error:". If the number is zero no error has occurred.

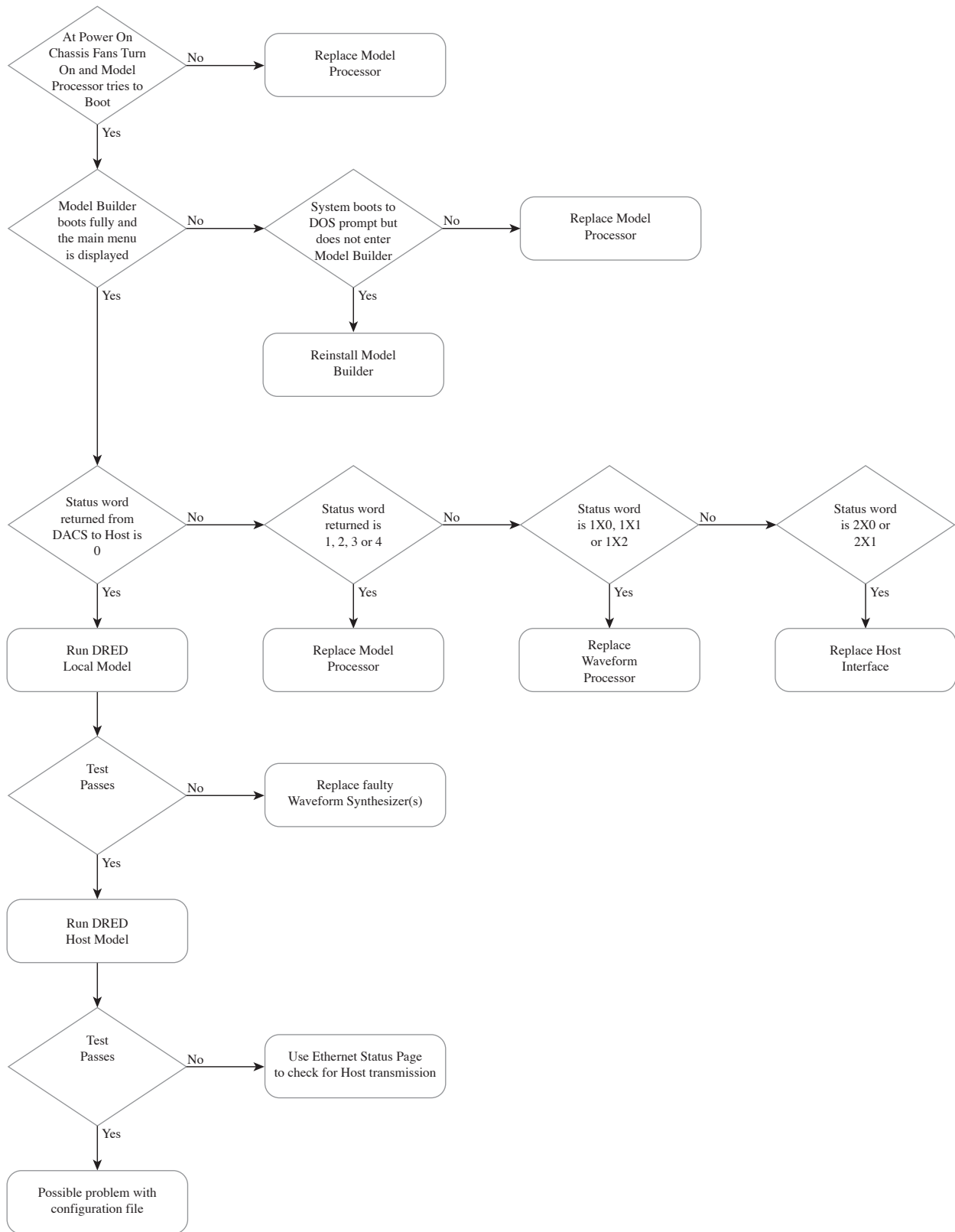

Remove and Replace

Should it become necessary to remove and replace one of the DACS modules, use the following procedures.

**** CAUTION ****

Replacing hardware in any system can void any hardware warranty. If your system is under a hardware warranty, please contact ASTi before proceeding with any repairs.

**** WARNING ****

Potentially fatal voltages exist in the DACS. Before entering and removing any component from the DACS, be sure to turn off all power to the DACS and disconnect the electrical power cord.

**** CAUTION ****

All DACS components are ESD sensitive. When removing, handling, replacing, or storing DACS components, proper ESD procedures must be observed. Failure to take effective ESD precautions can result in damage to equipment. Always make sure you are properly grounded when handling DACS modules. Modules should be fully enclosed in anti-static bags when transported and stored.

2U Chassis: Model Processor

For the 2U Chassis, spare Model Processors include the chassis, disk drives, CPU, power supply, and everything else that is not plugged into the ISA bus. Because of this, the removal and replacement must be done at the same time, and consists of removing all cards except the CPU from the Model Processor chassis and installing them in the spare Model Processor.

Spare Model Processors are shipped with the hard disk partitioned and formatted. The Model Builder application software, DOS operating system and other 3rd party software are not installed on the spare module. If the user wishes to configure the spare module as a hot spare, there is no restriction on installing the Model Builder Application Software on the model processor. Installation of the DOS operating system and other 3rd party software is subject to the 3rd party vendor software license agreement.

EQUIPMENT REQUIRED:

- Phillips #1 Screwdriver
- Original Software Disks for all Software Supplied

REMOVAL AND REPLACEMENT:

- If possible, back up the Model Processor hard disk.
- Perform Power Down Sequence described in Chapter 4, DACS Operation.
- Before proceeding, take care that ESD precautions are observed by ensuring that both you and the equipment are properly grounded.
- Disconnect all cables from the system.
- Remove the top of the chassis from the spare system. This will require the removal of the screws holding it on, which will be located on the front, back, top, and/or sides of the chassis.

- Remove the top of the chassis from the original system. This will require the removal of the screws holding it on, which will be located on the front, back, top, and/or sides of the chassis.
- Lift the inner card frame and backplane assembly out of the chassis taking care not to stress any of the power cabling. Do Not remove any of the power cabling to the backplane. Turn the assembly slightly and rest it on the main chassis assembly. Repeat this step with the spare Model Processor chassis.
- For each card in an ISA bus slot (except the CPU card), remove the screw securing the card to the chassis.
- If there is a ribbon cable connecting some of the cards together, remove it. Remember where it was connected: it will have to be reinstalled.
- For each card in the old model processor, remove the blank mounting bracket in the corresponding slot of the spare model processor. This is done by unscrewing the screw on the top of it holding it in place.
- Remove each card from the old model processor and reinsert it into the new chassis. Place the cards in the same location in the new chassis to avoid any confusion.
- If there was a ribbon cable connecting cards together, reinstall it.
- Secure the mounting brackets of the cards by screwing them to the chassis. There is one screw securing each card.
- Place the card assembly carefully back in the chassis, taking care to avoid any pinched cables.
- Replace the top of the chassis to the spare system and install the screws.
- Reattach all cables.
- Insert the DOS installation disk in the A: drive.
- Perform power up sequence described in Chapter 4, DACS Operation.
- When the A: prompt is displayed, perform the cold start procedures listed in the following section starting from the Operating System Installation section. For convenience, all spare Model Processor modules have the CPU BIOS preset and the hard disk partitioned and formatted before shipment.
- Restore back up of user created files and directories.

The DACS is now ready for use.

Network Cards

The following procedures apply to all DACS models for both the Host Interface and DIS/HLA network interface cards.

EQUIPMENT REQUIRED:

- #1 Phillips Screwdriver
- Software Protection Disk for replacement ethernet card

REMOVAL:

- Perform Power Down Sequence described in Chapter 4, DACS Operation.
- Before proceeding, take care that ESD precautions are observed by ensuring that both you and the equipment are properly grounded.
- Disconnect all cables from the DACS.
- Using the Phillips screwdriver, remove the screws holding the top of the chassis in place. Check the front, top, rear, and sides of chassis for locations of the screws, which may vary from system to system.
- Unscrew the screw holding the host interface card in place. Gently pull the card out of the slot, rocking it back and forth slightly, if necessary.
- Place the card in an anti-static bag for ESD protection.

INSTALLATION:

- Perform Power Down Sequence described in Chapter 4, DACS Operation.
- Before proceeding, take care that ESD precautions are observed by ensuring that both you and the equipment are properly grounded.
- Remove replacement card from anti-static bag.
- **For legacy 10Mbs Ethernet**, check the replacement card for the correct configuration. Either duplicate the jumper settings with the card being replaced, or if replacing Host card, then set jumper on #3 "I/O=300, IRQ=10." For the DIS card, set jumper on #2 "I/O=280, IRQ=3."
- **For 100Mbs Ethernet**, no addressing is necessary. It is performed during system start-up.
- Insert the card in the slot that was occupied by the old card.
- Secure the card by screwing the securing bracket to the chassis.
- Reinstall the DACS chassis cover on the system and put the screws back into place.
- Reinstall all cables.
- Perform power up sequence described in Chapter 4, DACS Operation.
- Exit the Model Builder software environment

- **IMPORTANT!** For proper Model Builder operation, verify you have the correct Software Protection Key Disk by comparing the system serial number (located on the back of the chassis) with the serial number printed on the disk. Follow the installation instructions below.

Insert the Software Protection Key code Disk in the A: drive.

Change to the A: drive and

Type 'install'

NOTE: This process installs the correctly coded software options file in the C:\MBUILDER\BIN directory. Multiple options files may be installed in order to support removable drives across many platforms.

- Reboot the system and examine the Errors page in the Model Builder software environment. There should be no error message indicating missing or invalid options key.

Waveform Synthesizer and TDM Controller Cards

The following procedures apply to all DACS models for both the Waveform Synthesizer and TDM Controller cards.

EQUIPMENT REQUIRED:

- #1 Phillips Screwdriver

GENERAL INFORMATION:

Each Waveform Synthesizer and TDM card has both jumpers and a rotary switch for address selection. One, and only one, card must be jumpered as a “Master” card. The rest should be jumpered as “Slave” cards. When TDM and Waveform Synthesizer cards are present together in the same chassis, the TDM card will always be the Master.

In addition, the rotary switches should be set to 6 and 1, 6 and 2, 6 and 3, etc. 6 and 1 will be DSP number one, 6 and 2 will be DSP number 2, etc. DSP number one should be jumpered as the master. Each card must have a unique address

All systems that are sent from ASTi will be correctly configured. If a card is being replaced, the simplest thing is to duplicate the settings of card being replaced.

Consult your engineering drawings for additional configuration information.

REMOVAL:

- Perform Power Down Sequence described in Chapter 4, DACS Operation.
- Before proceeding, take care that ESD precautions are observed by ensuring that both you and the equipment are properly grounded.
- Disconnect all cables from the system.
- Using the Phillips screwdriver, remove the screws holding the top of the chassis in place. Check the front, top, rear, and sides of chassis for locations of the screws, which may vary from system to system.
- Unscrew the screw holding the synthesizer or TDM card in place.
- If there is a ribbon cable connecting the card to other cards, remove it. Make a note of which cards were connected by the ribbon cable, because you will need to reinstall it.
- Gently pull the card out of the slot, rocking it back and forth slightly, if necessary.
- Make a note of the Jumper settings and settings on the two rotary switches. The replacement card will need to be set identically.
- Place the card in an anti-static bag for ESD protection.

INSTALLATION:

- Perform Power Down Sequence described in Chapter 4, DACS Operation.
- Before proceeding, take care that ESD precautions are observed by ensuring that both you and the equipment are properly grounded.

- Remove replacement card from anti-static bag.
- Set the jumpers and the positions of the rotary switches to the same settings as the old card.
Improper settings will prevent the system from working properly.
- Insert the card in the slot that was occupied by the old card.
- Reinstall the ribbon cable, if there was one. Make sure it is attached to the same cards that it was before.
- Secure the card by screwing the retaining bracket to the chassis.
- Reinstall the DACS chassis cover on the system put the screws back into place.
- Reinstall all cables.
- Perform power up sequence described in Chapter 4, DACS Operation.

RIU Version 4.1

EQUIPMENT REQUIRED:

- None

REMOVAL:

- Unplug all connectors to the RIU. Unplug the power from the RIU.
- The RIU is now removed.

INSTALLATION:

If a unit with factory default configuration is being used (i.e. the user has not changed any of the input gain jumpers) then perform the following procedure.

- Set the rotary address switch on the RIU face plate to the same number as the RIU you are replacing.
- Reconnect all external cabling.
- Reconnect power.
- If the user has changed any of the input gain jumpers, then perform the following procedure:
- Make sure that you are properly grounded for ESD protection.
- Unscrew the screws in the faceplate on the side with the TDM link connectors (opposite of the side with the DB9 audio connectors) and remove the faceplate.
- Slide the cover of the case off.
- Locate the gain jumper blocks near the DB-9 connectors. Match the gain jumper settings between the old and replacement RIU.
- Slide the cover back onto the case.
- Replace the end of the case and put the screws back in.
- Reconnect all external cabling
- Plug in the power cord.

If, for any reason, you decide to remove the board from its enclosure, remove the ground plug screw first.

Returns

If it becomes necessary to return equipment to ASTi for repair please observe the following instructions:

Call ASTi for an RMA number, or submit your request via the ASTi website. The receiving department at ASTi will not receive anything without an RMA.

When packing the equipment in question make sure it is well protected. Always **DOUBLE BOX**. Individual cards or modules should be properly enclosed in antistatic bags to prevent possible ESD damage. **DO NOT** ship monitors unless they are the item to be evaluated. *Failure to properly package equipment could void warranty.*

Do not include the accessory pieces such as power cords, software and mounting brackets. Only send back items that do not work.

The shipping label must include the RMA number.

Include a description of the problem including the serial number for the unit in question and a point of contact. Failure to include a point of contact will delay return of equipment.

Note that if equipment is not under warranty a Purchase Order will be required to cover any repairs. ASTi will provide a quote for all non-warranty items.

Equipment will be shipped back via UPS ground unless otherwise directed. If it is a non-warranty repair shipping charges will be billed.

Cold Start

This section provides a complete disk preparation and software installation procedure for the Digital Audio Communication System (DACS). Follow steps in each section in order. Certain sections may not apply depending on the configuration and software supplied with the system.

Total execution time is approximately 30 minutes.

Note: If using a MicroDACS, refer to the document “ASTi MicroDACS Cold Start Procedure”.

**** WARNING ****

The cold start process will destroy all data currently on the DACS hard drive. Backups of any data not installed by the cold start process should be performed prior to proceeding.

Required Equipment

The following is required to perform the Cold Start procedure

- Original DOS installation disks.
- Original ASTi MODEL BUILDER Installation and Utilities disks.
- Any 3rd party software disks delivered with the DACS (some systems maybe provided with additional software such as type back up).
- Original ASTi Software Protection Key Disk
- Original ASTi Custom Model disks (On systems where ASTi has provided custom sound models.)

Procedure

The standard steps required to perform a Cold Start are:

BIOS Set Up

Hard Drive Partition and Format

Operating System Installation

Model Builder Software Installation

Model Builder Utilities Installation

Software Protection and Options Selection Key Installation

ASTi Custom Model Installation (If Custom Model included)

User Custom Model Installation

To perform a complete cold start, these steps need to be followed in order. Each step is described in detail below.

BIOS Set Up

BIOS versions may differ from system to system depending on the platform. In general the default settings should be used when setting up the BIOS. Deviations from the default settings are noted in Appendix A by BIOS type and revision.

After the BIOS is properly configured, save the configuration and exit. To speed the cold start process, insert Disk 1 of your operating system diskettes in the A: drive before exiting so that the system may boot from the floppy.

After the BIOS is configured the system is ready for disk partitioning and formatting.

Hard Drive Partition and Format

Systems with MS-DOS or PC-DOS: Systems with MS DOS or PC DOS operating systems should use the FDISK command to partition the hard drive and the FORMAT command to format the disk. The user should first boot the system using MS (or PC) DOS disk 1. If the disk has never been formatted or partitioned then automatic partitioning and formatting will occur. The user may also choose to exit this process and use the FDISK and FORMAT commands directly from the A: prompt.

For the purposes of cold starting the system with a hard disk already containing information, first format the hard disk by booting from MS (or PC) DOS disk 1, exiting the installation program and then using the FORMAT command. After the disk has been formatted, proceed with the operating system installation.

The disk will be partitioned appropriately as part of the process. If at any time you need to use the FDISK command to partition the disk, perform the following:

- Delete any existing DOS partitions
- Create a single new DOS partition
- Make the new partition the primary partition using all available sectors on the disk.
- Make the partition bootable.
- Format the disk. **Note:** Formatting can take several minutes depending on the disk size and processor type.
- Enter disk label if desired.

At this point hard disk preparation is complete.

Operating System Installation

MS DOS or PC DOS Installation: Use this procedure for installing the MS (or PC) DOS operating system.

If you have just completed hard disk preparation from within the MS (or PC) DOS installation environment, proceed with MS (or PC) DOS installation as prompted. If not, place MS (or PC) DOS disk 1 in drive A: and reboot the DACS using [Cntrl][Alt][Del].

Follow the installation prompts using all default settings until all the MS (or PC) DOS disks are installed (Installation of the Supplemental Disk is not required for MS DOS). When installation is complete, reboot the system.

Note: MS DOS uses 3 disks for system installation while PC DOS uses 6 disks for system installation.

At this point the system is ready for installation of any 3rd party software included with the DACS.

Note: Adding new hard disk drives to older systems may raise problems between the single-board computer (SBC) and the new drive. If the system has an SBC manufactured prior to 2000, check to ensure the system will be able to “see” the drive.

Model Builder Software Installation

Boot the system up into DOS.

Insert the MODEL BUILDER INSTALLATION disk into the floppy drive.

Type:

```
a:  
install
```

Follow the directions displayed on the screen. When installation is complete, go to the next section.

NOTE: The first time model builder is run, it creates a file called DISPLAY.REZ. This takes several minutes to complete and will generate a warning message. This process should not be interrupted.

Model Builder Utilities Installation

Boot the system up into DOS.

Insert the MODEL BUILDER UTILITIES INSTALLATION disk into the floppy drive.

Type:

```
a:  
install
```

Follow the directions displayed on the screen. When installation is complete, go to the next section.

Software Protection and Options Selection Key Installation

Insert the ASTi Software Protection Key Disk into the floppy drive.

Type:

```
a:  
install
```

Follow the directions displayed on the screen. When installation is complete, go to the next section.

Note: After installing Model Builder, MB Utilities and Options, press [ctrl]+[alt]+[del] to reboot. Allow Model Builder to build the display.rez file before proceeding.

Custom Model Installation

Use the following procedure for installing ASTi supplied custom sound models when provided with the DACS. If ASTi supplied custom sound models are not included with the system, proceed to the next section.

Note: *ASTi Custom Sound Model disks should always be installed after Model Builder Software installation to ensure proper loading of sound models at boot up.*

- Insert Disk 1 of Custom Model Disk set in drive **A:**.
- Change to the **A:** drive and type '**Install**'
- When installation is complete, remove the disk.
- Continue this process until all disks are installed.

When all Custom Model disks are installed, go to the next section.

Cell Routing Configuration File Installation

Use the following procedure for installing ASTi supplied cell routing configuration file(s). These files will be required when control panels are attached to RIUs and ASTi state machines are part of the overall system solution.

If this situation does not apply, proceed to the next section.

Note: *Cell routing configuration files may also be included with custom model delivery instead of on separate disks. Files should always be installed after Model Builder Software installation to ensure proper loading of sound models at boot up.*

- Insert Disk in drive **A:**.
- Change to the **A:** drive and type '**Install**'
- When installation is complete, remove the disk.

When installation is complete, go to the next section.

User Generated Model Installation

After all application software provided with the system has been installed, the user should at this time install his/her own sound models, sound files, subdirectories, or other modifications.

Model Builder Software Updates

If you receive a Model Builder software update, follow the model builder installation procedures listed in the Cold Start section above.

During installation both the root and C:\MBUILDER\BIN directories are saved to directories ROOT.SAV and C:\MBUILDER\BIN.SAV. If you have made changes to your *autoexec.bat* or *config.sys* be aware that these files will be replaced by Model Builder's standard *autoexec.bat* and *config.sys* files during installation. You will need to update these files with your changes after Model Builder is installed.

Note: *Systems provided with ASTi custom sound models will require reinstallation of the model disks AFTER Model Builder installation to ensure correct sound model loading at boot up. (Reloading the model disks installs the correct autoexec.bat.)*

Appendix A: Interface Definition

This Appendix summarizes the interface specifications for all components associated with the DACS including the various card types which can be installed in the main chassis as well as some of the external components offered such as RIUs and AIUs.

Additional interface information can be found in the engineering drawings shipped with the system, various application notes, and individual user/installation guides shipped with the equipment

Model Processor Interface

The Model Processor includes the chassis, power supply, backplane, CPU, floppy and hard drive.

Power

Connector Type:

Standard 3 pin IEC connector is used for AC Power. The power supply is either autosensing or switchable between 115 and 230VAC.

Current Requirements:

The DACS draws less than 4 A from a 115V 60 Hz earth grounded, three wire utility outlet with no monitor connected. Typical monitors usually draw between 1 and 2 amps at 115V.

Video

Video connection is made through a female 15-pin subminiature “D” connector. The video signal is VGA. The video connector is in the rear of the chassis.

Keyboard

For 2U and 4U systems, the keyboard connection is made either through a 5-pin DIN (AT-style) located on the front or rear of the chassis or via a 6-pin mini-DIN (PS/2-style) located on the CPU card itself. Any standard 101 key PC keyboard can be used, however, the connector type should be checked to ensure that no adapter is needed.

For MicroDACS systems, the keyboard connection is made through the USB connector on the CPU. A standard, 101-key USB keyboard may be used.

Chassis

The 2U chassis is a 3.5”- high, 19” rackmountable chassis, which is approximately 17 inches wide (without rackmount brackets) and 17.5 inches deep.

The 4U chassis is a 7”-high 19” rackmountable chassis, which is approximately 19 inches wide and 17 inches deep.

While both chassis styles can be bolted directly to rack rails, it is recommended that additional angle brackets be installed beneath the unit for easier installation and support.

The MicroDACS chassis is a 2.3”-high chassis, which is approximately 6.5 inches wide and 5.4 inches deep. The MicroDACS can be rackmounted in a separately-purchased, 2U-high rackmount bracket, which can accommodate two MicroDACS systems.

See Appendix B for additional mechanical information.

Waveform Synthesizer Interface

Connector Type: The analog I/O connector is a female 37 pin subminiature D type.

Bandwidth: 0 to 22 kHz depending on the user selected sample rate.

Noise Level: At least 50 dB below nominal signal level of 0 dBm at 1 kHz

Crosstalk: At least 50 dB below nominal signal level of 0 dBm at 1 kHz

Output Drive: Compatible with an amplifier's balanced input impedance of 600 ohms or greater, and a maximum output capability of 6Vp-p.

Input: Compatible with an amplifier's balanced output impedance of 600 ohms or less, and capable of receiving a maximum 3Vp-p signal.

Connector Pinouts: Connector pin out for the Waveform Synthesizer is shown in Figure 9.

Figure 9: Audio Connector Pinout

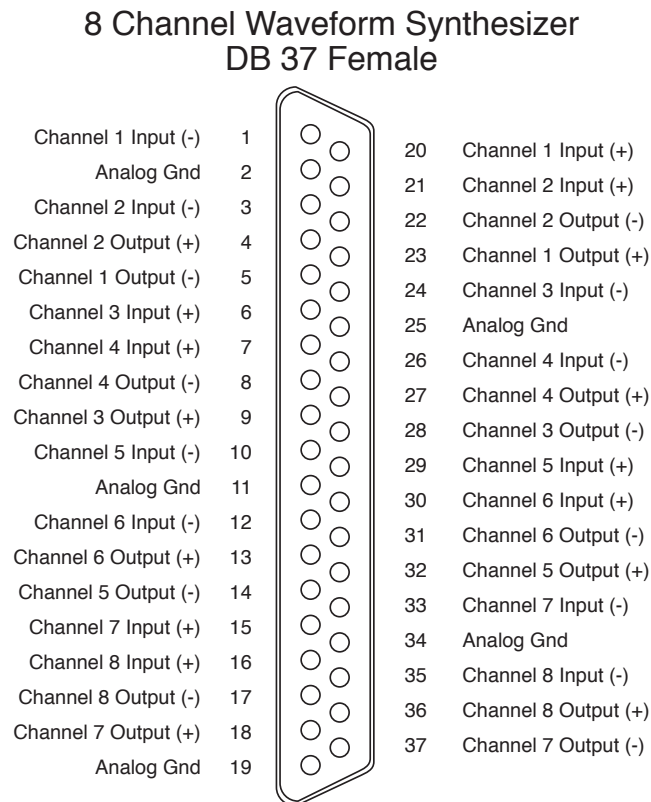

TDM Controller Interface

Connector Type: Two RJ45 connectors

Cable Interface: Standard category 5 UTP network cable

Remote Interface Unit

Power Requirements

Version 4.1:

The RIU uses less than 200mA of current at 5V. A power cord with a built in AC/DC converter is supplied with each RIU. The converter will draw less than 100 mA at 120V.

Mechanical Layout

The RIU enclosure measures approximately, 1.5” by 5.5” by 7.5”. Connectors are located on both ends of the unit. Four female DB 9 connectors located on one end provide the audio and digital I/O interface for either two or four channels depending on the configuration purchased (only the first two connectors will be present on two channel versions).

The opposite end are connections for power, two serial ports, and TDM ring connections.

A drawing of the RIU is given in Appendix B, “Mechanical Layout”.

No additional mounting hardware is provided with the unit. A 19” rack mount kit which will accommodate up to three RIUs in 1U of rack space is also available.

Audio Connector Pinout

Figure 10: Audio Connector Pinout Version 4.1 RIUs

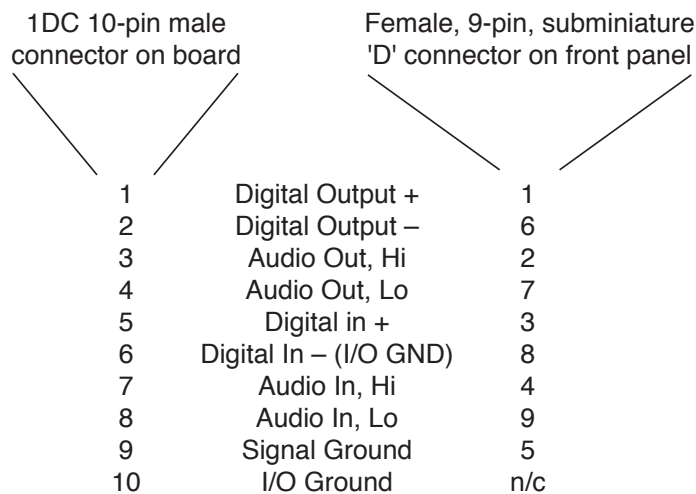

TDM Ring Interface

The RIU interfaces to the TDM ring through two RJ-45 connectors located on the end of the RIU enclosure. RIUs and the TDM controller are interconnected in a ring which begins and terminates at the controller with standard Category 5, UTP (10BaseT) network cable.

Indicator Lights

There are two indicator lights on the RIU - the sync light (a green LED) and an error light (which is a red LED). Both are located next to the TDM RJ-45 connectors (see drawing in appendix D).

The error light will come on steady if no sync signal is being received by the RIU. (For example, when the RIU is powered on, but not plugged into the TDM loop). If the red LED is flashing, then the TDM ring has sync pulses, but the RIU cannot synchronize with the Model Builder software.

The RIU must synchronize with a clock signal on the TDM ring, and cannot pass any sound or data until it has done so. At power-up, the RIU attempts to synchronize. If the green LED is rapidly flashing, then the RIU's physical address is higher than what the model supports.

When the RIU is synchronized, the sync light will blink at 1 Hz. The sync lights of different RIUs might be out of phase - one being on while the other is off. This is normal. At higher sample rates, the green LED will blink at a faster rate.

Audio I/O

Audio input is capacitively coupled and balanced with an input impedance of $> 1k\Omega$.

Input gain for each channel is settable to 1, 10, 100 or 1000 by changing a jumper on the circuit board.

RIU Version 4.1:

The maximum input voltage is 4.5Vp-p.

The maximum output voltage power is 1W RMS into a bridge-connected 8Ω load. When driving single-ended loads, the maximum output power is 250mW into an 8Ω bridge load.

Digital Input

Each digital input is a contact sensing input. It is triggered when the DI (pin 3) is shorted to one of the grounds (pins 5 or 8). The DI input is connected to an internal pull-up resistor to 5V. To use a DI circuit, connect a single-pole/single-throw switch between DI and a ground pin.

The model will respond to the digital input within one model frame. However, the digital input will not respond to more than one change in a 50 ms period.

Digital Output

The digital output, when active, shorts the DO (pin 1) to ground. DOs are opto-isolated. The digital output will respond to a change in the model within one frame. However, it can not be changed more than once in a 50 ms period.

See also ASTi application note for interfacing to RIU DIs and DOs.

Network Interface

Connector Type: RJ45 (100BaseT)

Specification: The DACS, as a standard product, supports the Ethernet IEEE 802.3 standard.

The card is 10/100 Mbs autosensing, and can be used for either 10 or 100 Mbs networks.

Interface: The DACS supports UDP level protocol. IP format addressing is used under UDP.

For receipt of state information from simulation applications the Model Builder runtime environment supports a wide variety of data formats including floating point, boolean, ascii, and fixed point signed and unsigned integers of varying lengths, etc. Support is provided for big endian and little endian formats and IEEE and Gould/Encore format floating point numbers. Boolean flags can be either bit or byte variables.

The layout of the packet can be that which is most advantageous for the host computer, since each input object has its variable defined as a byte (and bit if applicable) offset from the start of the packet. This avoids the need to group similar variable types together to ensure a consistent type / word alignment.

For receipt and transmission of DIS format PDUs, the Model Builder application software supports DIS 2.03, 2.04, and IEEE releases of the standard.

For receipt and transmission of cell based data the format is an ASTi proprietary format. Cell data transmitted over the network interface is bundled in a standard UDP format packet.

I/O Interface

The following sections provide interface information about all I/O cards available for the DACS.

Digital Input/Output

Connections: The digital input/output card interfaces through a male DB 37 connector as shown in figure 14. Eight digital inputs and eight digital outputs are available.

Digital Input: The digital input port on the DI/DO board uses optically isolated sensors to sense whether an externally applied voltage is on or off.

To sense an external voltage, connect the voltage source between a pair of input pins (for example: High In 0 and Low In 0). The DI/DO board is configured to sense voltages between 4.1 VDC (minimum turn-on voltage) and 15.8 VDC (damage threshold voltage). The applied voltage must supply a current of at least 3 mA.

Digital Output: The outputs are reed relays. When an output is triggered, the A and B pins for the output will be shorted through the reed relay. There is no polarity for these outputs. Loads of more than 10 Watts should not be driven through these relays. Also, inductive loads such as motors should not be driven through the relays. An overcurrent can permanently fuse the relays closed.

Figure 11: Digital Input/Output Connector Pinout

Digital Input/Output Connector Pinout
DB 37 Male

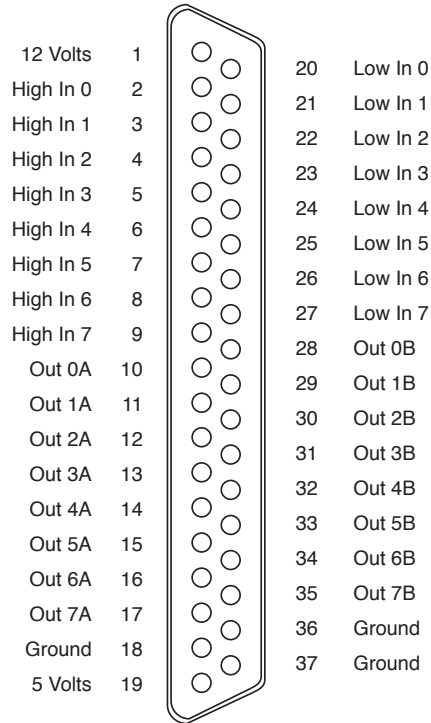

Appendix B: Mechanical Layouts

2U Chassis Mechanical Layout

Table 4: DACS 2U Chassis Dimensions

	Without Rackmount Brackets	With Rackmount Brackets
Height	3.5"	3.5"
Width	17.25" (incl. 1/8" screw protrusion, each side)	19"
Length (depth)	18.875" (incl. 1/8" screw protrusion, back)	18.875"
Allow at least 6" at rear of chassis for connector access and cable clearance.		

Figure 12: Front View of 2U Chassis

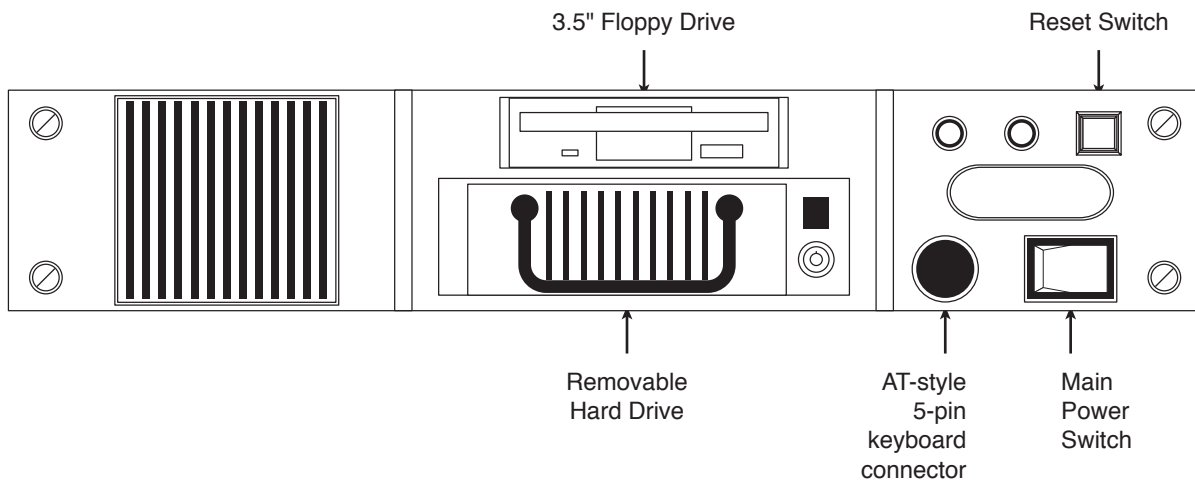

Figure 13: Rear View of 2U Chassis

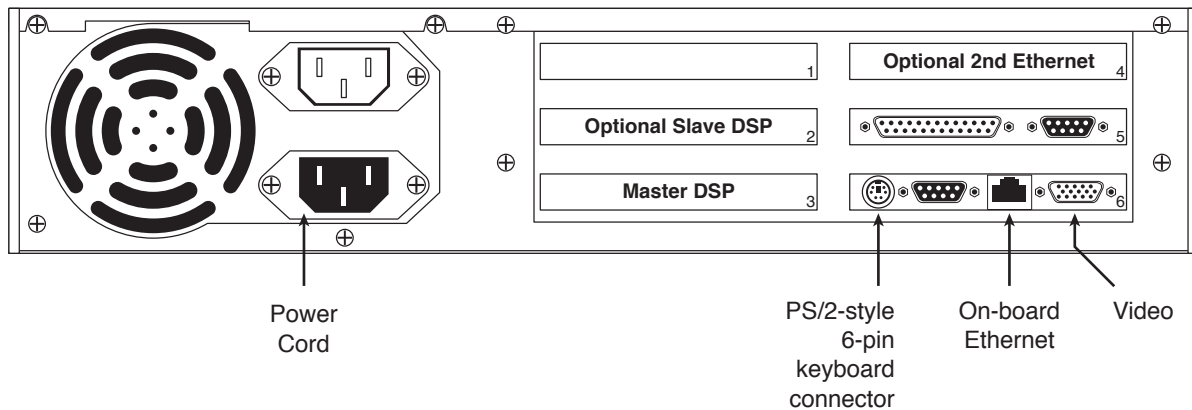
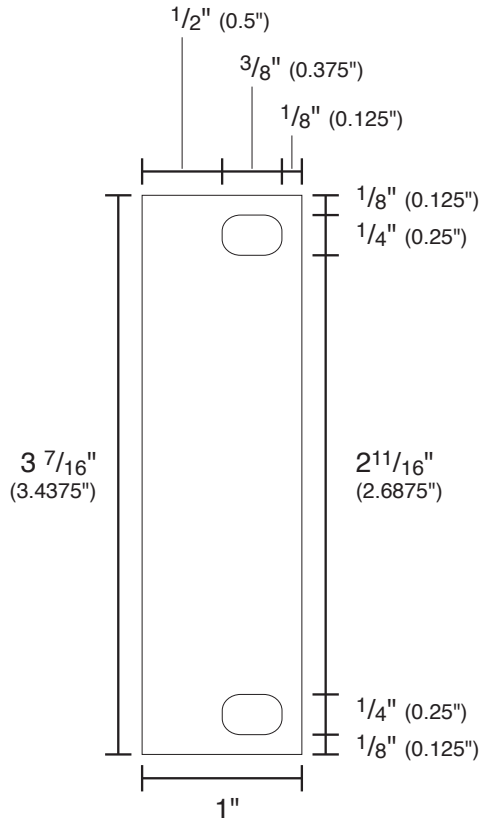
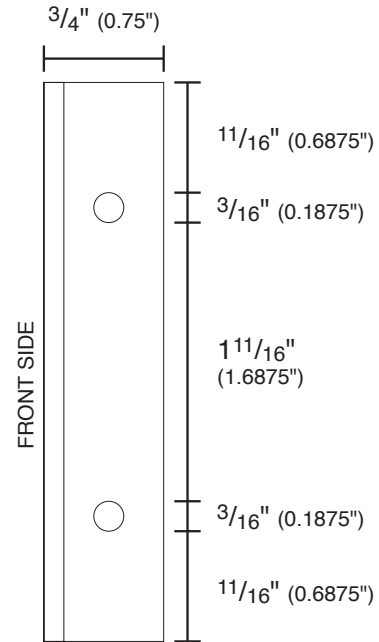

Figure 14: 2U Rackmount Bracket Specifications

FRONT



SIDE



4U Chassis Mechanical Layout

Table 5: DACS 4U Chassis Dimensions

	Without Rackmount Brackets	With Rackmount Brackets
Height	7"	7"
Width	17.25" (incl. 1/8" screw protrusion, each side)	19"
Length (depth)	17.25" (door closed, incl. lock protrusion)	19" (incl. 2" handles)
Allow at least 6" at rear of chassis for connector access and cable clearance.		

Figure 15: Front View of 4U Chassis, Door Removed

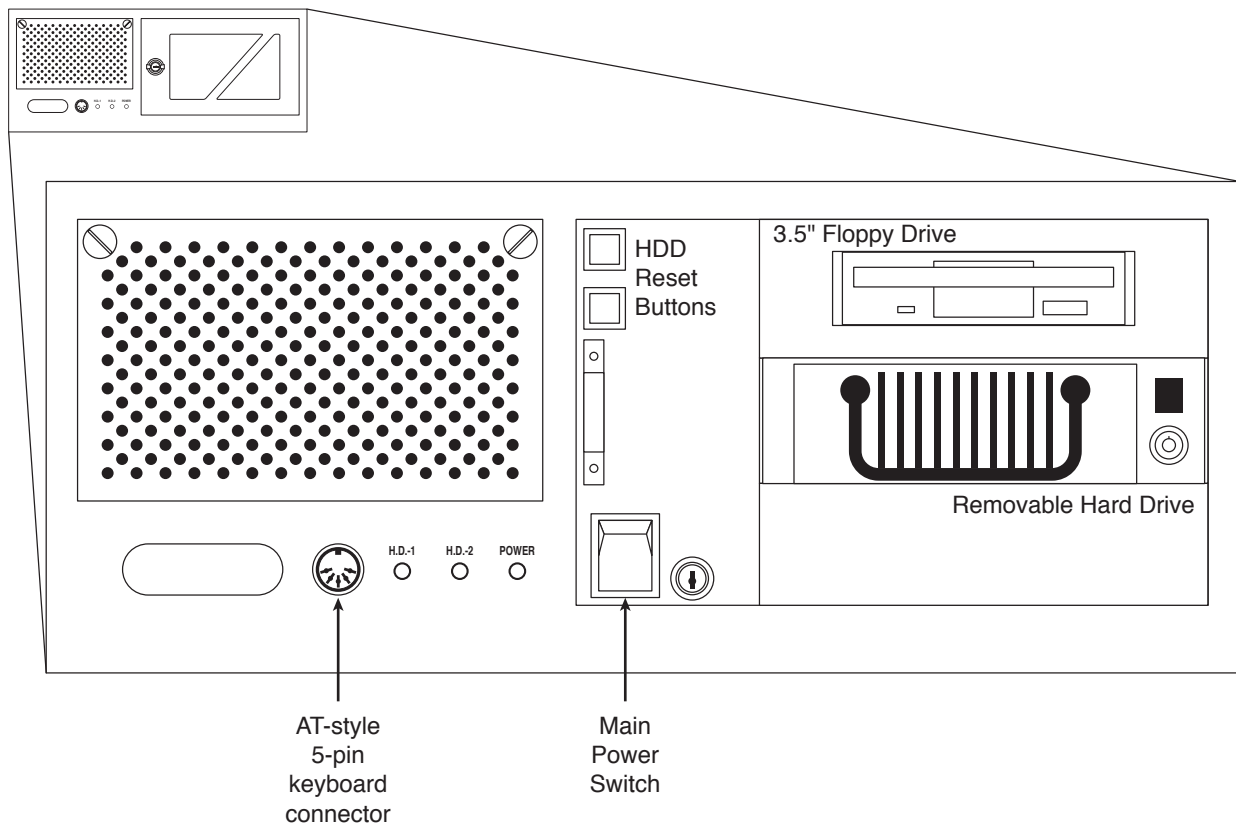

Figure 16: Rear View of 4U Chassis

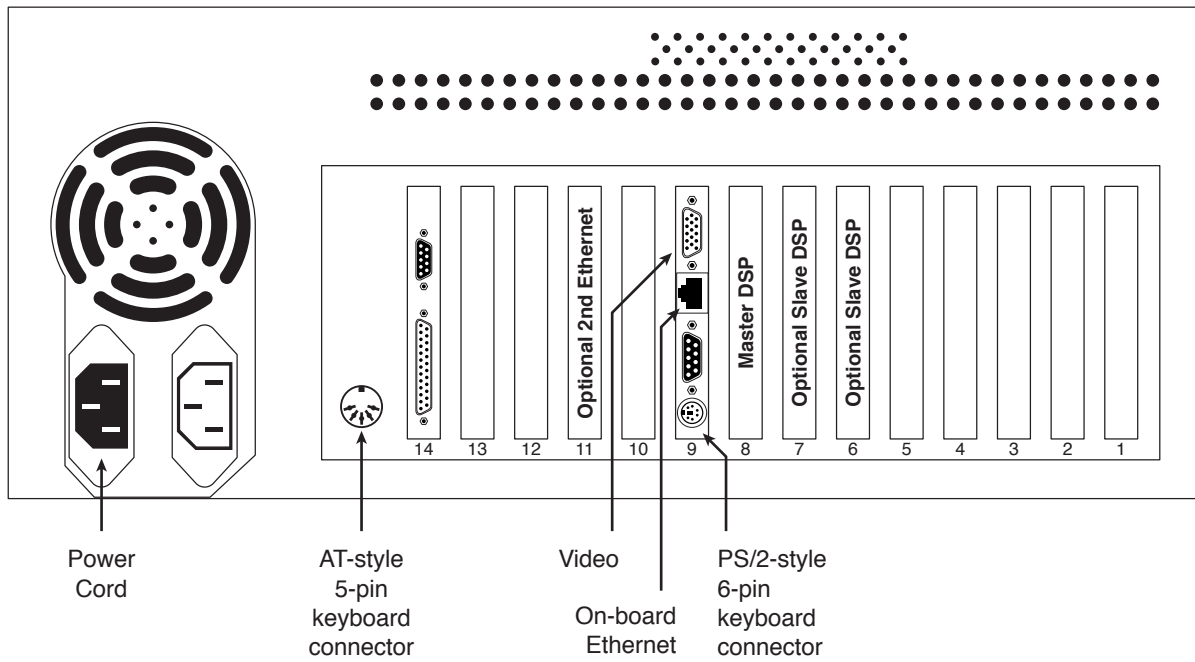
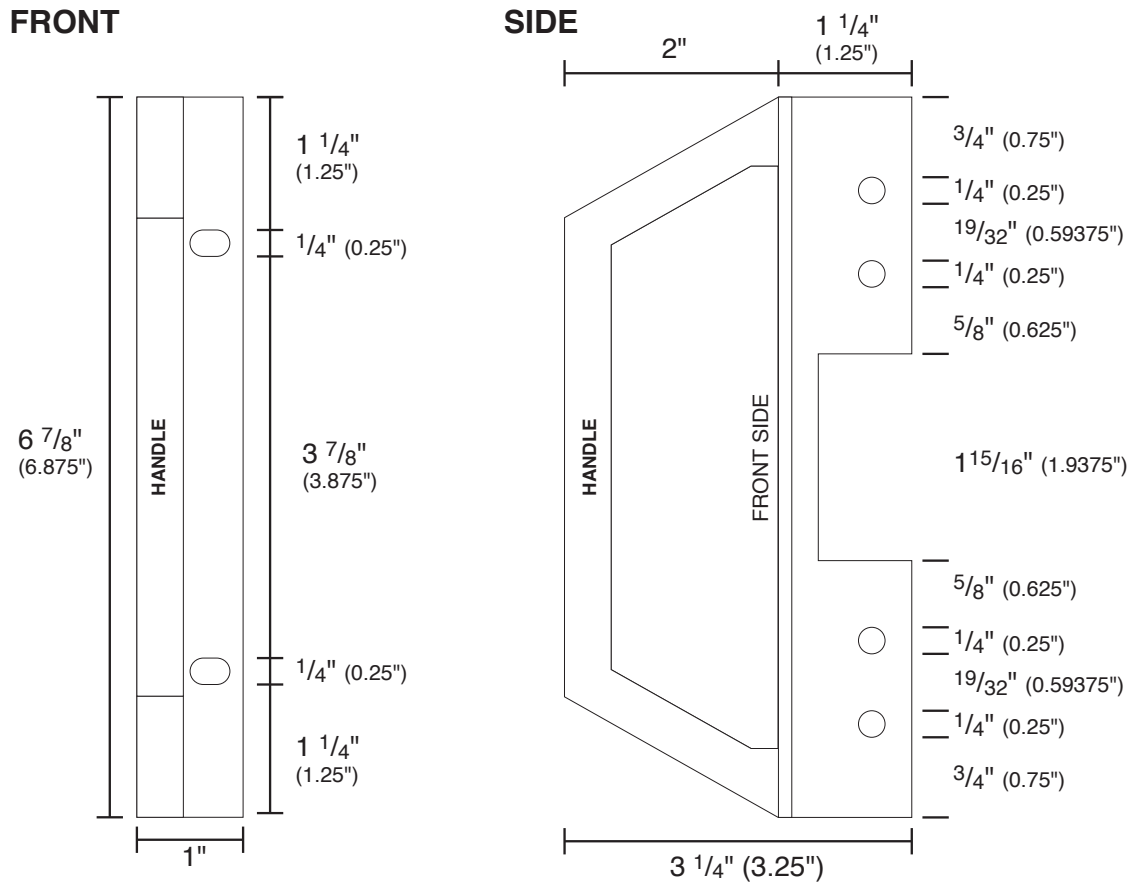

Figure 17: 4U Rackmount Bracket Specifications



MicroDACS Chassis Mechanical Layout

Table 6: MicroDACS Chassis Dimensions

	Outside Rackmount Bracket
Height	2.3125" (2 5/16")
Width	6.5"
Length (depth)	5.375" (includes front power switch 1/4" protrusion and rear power connector 3/8" protrusion)
Allow at least 6" at rear of chassis for connector access and cable clearance.	

Figure 18: Front View of MicroDACS Chassis

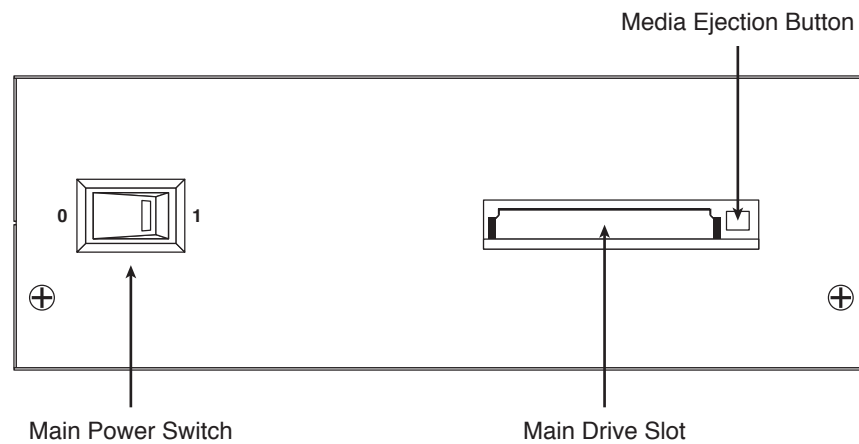
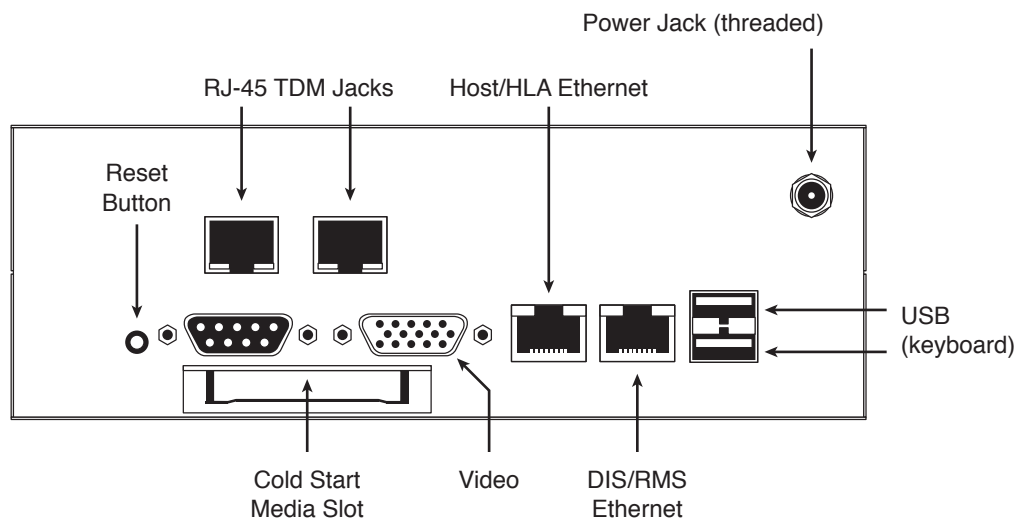

Figure 19: Rear View of MicroDACS Chassis



RIU Version 4.1 Mechanical Layout

Table 7: RIU Module Dimensions

	Outside Rackmount Bracket
Height	1.55"
Width	5.55"
Length (depth)	7.5"
Allow at least 6" at rear of enclosure for connector access and cable clearance.	

RIU Front Panel Face

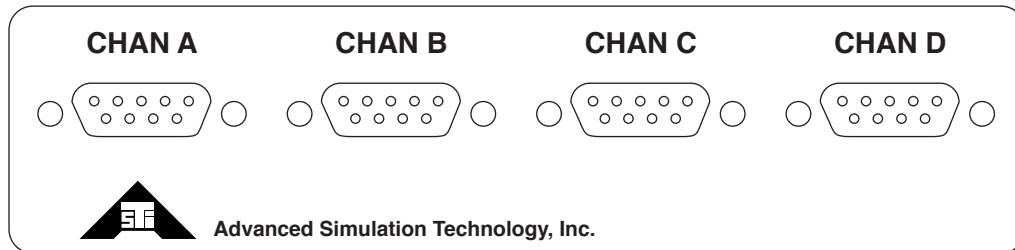

RIU Rear Panel Face

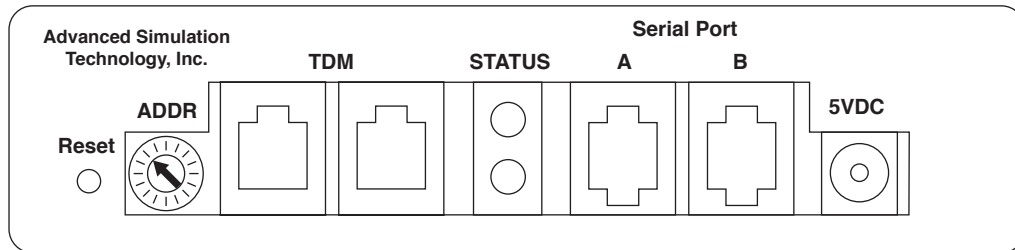

See Remote Interface Unit Version 4.1 Technical Guide (Document No.:ASSY-01-RIU04-MN-2) for more detailed information.

Distributed Digital Interface Mechanical Layout

Table 8: DDI Module Dimensions

	Single-Height Module	Double-height Module
Height	1.55"	2.55"
Width	5.55"	5.55"
Length (depth)	7.5"	7.5"
Allow at least 6" at rear of enclosure for connector access and cable clearance.		

Single-height DDI Panel Faces

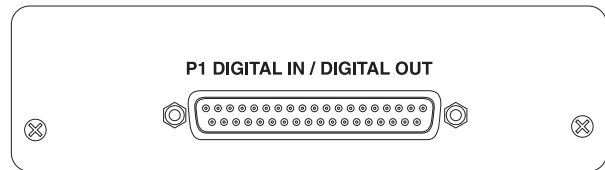
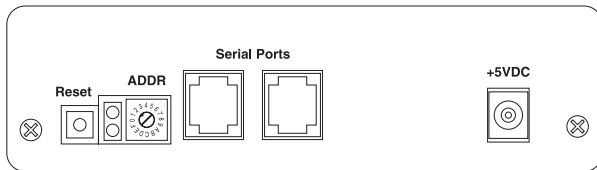

Double-height DDI Panel Faces

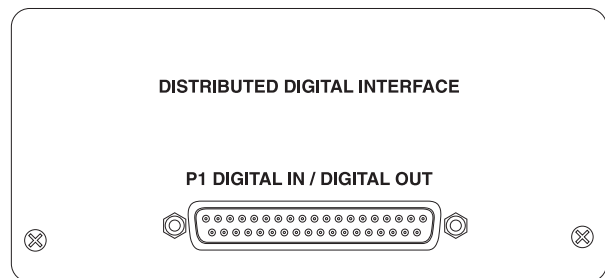
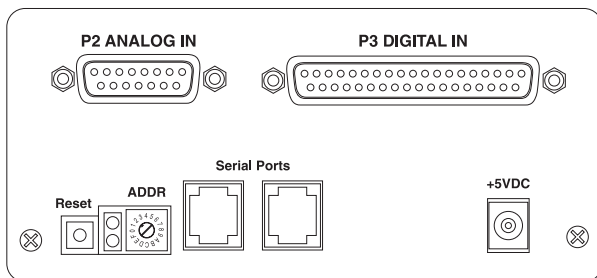

See Distributed Digital Interface Technical Guide (Document No.:ASSY-01-DDI-MN-1) for more detailed information.

Mechanical Layout AIU

AIU Front Face

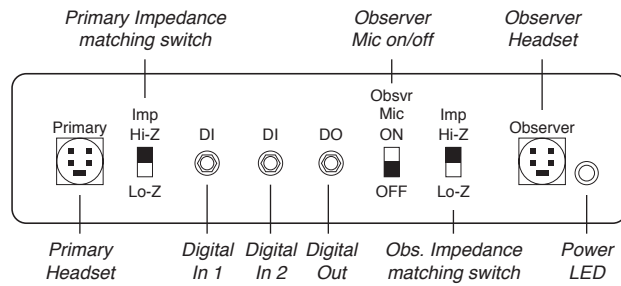

AIU Rear Face

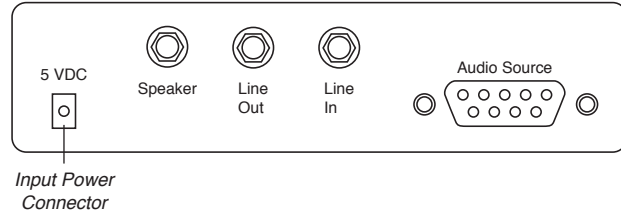

AIU Bottom Plate

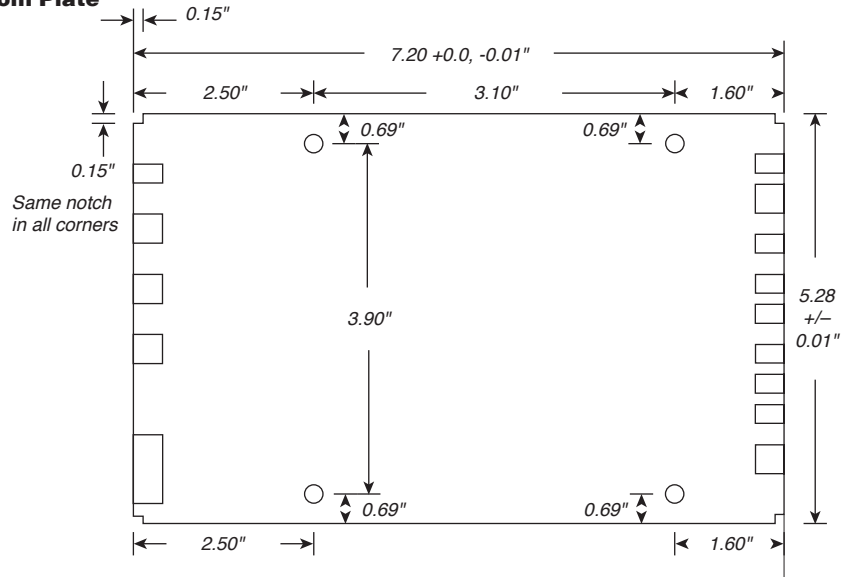

The AIU requires 1" of vertical clearance. The tallest components are the 1/4" phone jacks.

AIU Enclosure

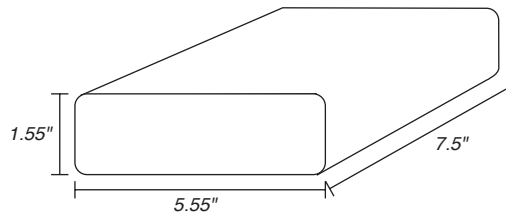

Note: This product has been obsoleted from the production inventory, but is included here for legacy support. Contact ASTi at 703-471-2104 for information about receiving legacy equipment documentation.

Appendix C: Common Problems

Problems with Waveform Synthesizer Audio I/O

PROBLEM:

One or more channels is dead - no sound is coming out.

SUGGESTION:

Run DRED_LOC by exiting to DOS and typing DRED_LOC. This will play a unique sound out of each audio output. If sound does come out of each channel now, you probably have a problem with your model.

If one or more of the output channels is still dead, check your cabling and make sure any powered speakers or intermediate amplifiers are turned on.

If you still get no sound, check the DSP Timing page (above) to see if all the cards are running properly. If they are, and you still get no sound, the card may need to be replaced.

PROBLEM:

Sound comes out of the outputs, but the inputs don't seem to be working or have a lot of noise in them.

SUGGESTION:

Check to see that your preamp gain is turned up if you are using a microphone. The preamp gain for each channel can be viewed in the "Gains" menu, which is in the "Waveform DSPs" menu. A typical microphone will require a gain of about 40. Use the '+' and '-' keys to adjust the gain.

To have the gain set at start-up, read the section of the Model Builder Reference manual titled "System Configuration".

PROBLEM:

Audio input from a piece of audio equipment (such as a CD player) to the DACS sounds very bad.

SUGGESTION:

Check to see that the preamp gain is set to 1. All line level sound into the DACS should not be amplified, or else clipping of the signal will occur.

Problems with Host Interface

PROBLEM:

Host computer and DACS are not communicating.

SUGGESTIONS:

Several things could be happening. Go to the Ethernet Status Window.

IF:

RX Good Count is incrementing and RX Errors is not incrementing.

THEN:

The DACS is properly receiving packets from the Host computer. Go to the Ethernet Control Window. The Pkts counter for one or more of the RX buffers should be incrementing. Make sure the buffer receiving the packets is the same one specified in the model. If none of the RX buffers are receiving, make sure the host computer is using the correct port address.

IF:

ARP request tx is incrementing, TX Errors is incrementing, and the rest of the counters are zero.

THEN:

Check to see that the cable attaching the host computer to the DACS is properly hooked up. If you are using coaxial cable, make sure it is properly terminated.

IF:

RX good count is not incrementing, TX Errors is not incrementing, and ARP reply rx is zero.

THEN:

Go to the Host Interface menu, then to the Ethernet Status page. Near the top of the page is a field called "Filter". Set this to "Promiscuous: All packets".

If the receive counters are still not incrementing, then there are no packets being sent on the network. Your host computer is either not sending packets or is not hooked up to the network.

If you see packets being received, you may have your IP addresses set up wrong. Make sure that the IP address that the host computer has for the DACS is the same IP address the DACS has for itself.

RIU Problems

PROBLEM:

I'm getting no audio out from one or more of my RIUs, or the digital inputs or outputs don't seem to be working.

SUGGESTION:

Quit Model Builder and go into DOS. Type DRED_RIU. This will load the RIU daily readiness model. Before loading, a screen will appear explaining what the model does and the modes it works in. The default is RIU #1, to test all RIUs on the ring, load the all_riu model or run the RIU_TEST routine.

The daily readiness model tests the audio inputs and outputs, as well as the digital inputs and outputs. It will allow you to determine if your problems are hardware based or part of the model.

PROBLEM:

I've run DRED_RIU, and I still get no audio from RIU #1.

SUGGESTION: Look at the back of the DACS at the TDM card. There are two LEDs. If one of them is not lit, it means that there is a break in the TDM ring (i.e. the cable daisy chaining the RIUs together and to the TDM card is not continuous.)

PROBLEM:

I've determined that the TDM ring is not continuous, but cannot locate the break.

SUGGESTION:

Load "All_RIU" model manually to see which RIUs the sound comes from. The break is after the RIUs generating audio.

PROBLEM:

I'm getting sound out of the RIUs, but one of the channels on an RIU sounds very noisy.

SUGGESTION:

This symptom can be caused if the RIU is powered up after the DACS. To correct it, leave the RIUs powered on and go to the "Restart" option of the main menu. This will reset the TDM ring.

PROBLEM:

The hardware all works when I run DRED_RIU, but in making my model I can't get the digital input to respond and the RIU number does not appear on the DSP timing page.

SUGGESTION:

There is no RIU input feeder for the RIU. Insert one into your model.

Miscellaneous Problems

PROBLEM:

When I start the system, only one DSP card is recognized, many of the Model Builder objects that I try to use say “DEMONSTRATION USE ONLY” or “DISABLED” at the top of them.

SUGGESTION:

From the Main Menu, go to “Host Interface”, then the “Status” or “Ethernet Status”, depending on which one appears.

If the phrase “KEY INVALID OR NO HOST INTERFACE PRESENT” appears, then one of two problems have occurred.

1. Check the “ID1” and “ID2” numbers at the bottom of the screen. If they both read 00-00-00-00-00-00, then no ethernet card is installed, or the ethernet card is faulty.
2. If the phrase “Credits exhausted at xxx” appears, then you are trying to load a model that consumes more credits than are enabled on your system.
3. In MB versions 4.06 and higher, the CPU on-board ethernet is active. The options file is keyed to the CPU ethernet address for these systems. If you attempt to run an earlier version of MB, the CPU address will not be read, and MB will report a failed options file. Contact ASTi for assistance in resolving this issue.
4. If some other number appears, than the options file, which enables the software, has the wrong code or is missing. If you change the host interface card, you need to install a new options file. All new options files can only be generated at ASTi. If you purchase a spare ethernet card from ASTi, the options files will be configured to recognize either the original or the spare ethernet card.

Appendix D: System Specifications

Temperature And Humidity Requirements

The DACS is able to operate in an environment of 50 to 90 degrees F, relative humidity of 10% to 70% non-condensing, and an altitude range of 0 to 8000 feet. Storage environments should be limited to a 32 to 135 degree F (0 to 55 C) range.

Chassis Cooling

2U and 4U Chassis

The 2U and 4U chassis are cooled with two fans - one for the power supply, and one for the chassis.

System Weight

2U Chassis

A typical system weighs about 23 lbs.

4U Chassis

A typical system weighs about 38 lbs.

MicroDACS Chassis

A typical system weighs about 4 lbs.

Reliability

The ASTi sound system has been designed to use the minimal complexity of electronic hardware, using the highest quality components. Special attention has been paid to the selection of traditionally less reliable elements such as the hard drive. To this end the DACS contains a hard disk with a MTBF of 250,000 hours. Typical system MTBF will be greater than 10,000 hours. These numbers are based on predicted values with actual field data being superior. Below is listed typical MTBFs for several line replaceable units.

Description	Part Number	MTBF
Model Processor	C12X-XXX	>60,000
Waveform Processor	C208-XX	>80,000
Host Interface	C30X-X	>250,000

Maintainability:

The selection of a passive backplane architecture and industrial format chassis greatly simplifies the replacement of any element within the DACS. This results in a quick LRU replacement time of under 15 minutes and Mean Time To Repair (MTTR) of less than 30 minutes for most components and most models.

Appendix E: Cold Start Support

AMI BIOS (c) 1992 Setup (486 Systems)

Note: BIOS date is located at the top of Main Utility page. For 486 systems with AMI BIOS (c)1992, perform the following for BIOS setup:

- Reboot the DACS and enter the BIOS setup routine
- Select “Auto Configure With BIOS Defaults”
- Select the “Auto Detect Hard Disk” option to generate the appropriate hard disk parameters
- Select the “Standard CMOS Setup”
- Enter correct time and date, check that the hard disk parameters have been identified, enable the floppy, and set keyboard for “Not Installed”
- Exit and select “Advanced CMOS Setup”
- Set the following:
 - Memory Test Tick Sound = Enable
 - Above 1MB memory option = Enable
 - Floppy seek at boot = Enable
 - Boot Sequence = A:, C:
- Verify the following settings:
 - Video Shadow & Cache = Shadow
 - Adaptor Shadow & Cache = Disabled
 - System Shadow & Cache = Shadow
- Exit and select “Peripheral Management”
- Set the following:
 - Programming option to Manual
 - On Board Floppy Drive to Enabled
 - On Board IDE to Enabled
 - (if system has a removable drive,
 - set this option to Disable)
 - First Serial Port Address to 3F8H
 - 2nd Serial Port Address to 2F8H
 - Parallel port Address to 378H
- Exit and select “Write to CMOS and Exit”

The system will save the configuration and automatically reboot.

Note: If MS DOS is to be installed next, place DOS Disk1 in a: drive.

AMI BIOS (c) 1995 Setup (586 Systems)

Note: BIOS date is located at the top of Main Utility page. For 586 systems with AMI BIOS (c) 1995, perform the following for BIOS setup:

- Reboot the DACS and enter the BIOS setup routine
- Select “Auto Configure With BIOS Defaults”
- Select the “Auto Detect Hard Disk” option to generate the appropriate hard disk parameters
- Select the “Standard CMOS Setup”, and set the following:

```
Enter correct time and date
Check that the hard disk parameters have been identified
Enable the floppy
Set keyboard for “Not Installed”
```

- Set the following drive configuration:
- ```
Pri Master = Auto
Pri Slave = Not Installed
Sec Master = Not Installed
Sec Slave = Not Installed
```
- Exit and select “Advanced CMOS Setup”, then set the following:

```
Quick Boot = Disable
Boot Sequence = A:;C:;CD ROM
External Cached = Enabled
C000, 16k Shadow = Cached
C400, 16k Shadow = Cached
Mouse Support = Disable
```

- Select “Advanced Chipset Setup”, and set the following:

```
IRQ 12/M Mouse Function = Disable
```

- Select “PCI/Plug and Play Setup”, and set the following:

```
Plug and Play Aware O/S = No
IRQ 10 = “ISA/EISA”
IRQ 11 = “ISA/EISA”
```

- Exit and select “Write to CMOS and Exit”

The system will save the configuration and automatically reboot.

Note: If MS DOS is to be installed next, place DOS Disk1 in a: drive.

## AMI BIOS (c)1996 Setup (586 Systems)

Note: BIOS date is located at the top of the Main Utility page. For 586 systems with AMI BIOS (c)1996, perform the following for BIOS setup:

- Reboot the DACS and enter the BIOS setup routine.
- Select “Auto Configure with Optimal Settings”, and choose “Y” for loading high performance settings.
- Exit and select “Standard CMOS Setup”, then set the following:

```
Enter correct time and date
Enable the 3.5" floppy drive
```

- Set the following drive parameters:

```
Primary Master = Auto (for removable drives(
- OR -
Press "Enter" to detect fixed HDD parameters
Repeat procedure for each HDD in the system or select "Not
Installed" in the remaining HDD fields.
```

Note: If “Dynamic Drive Overlay Error” is displayed after completing the BIOS settings and starting DOS, return to the Primary Master Setting and press “Enter” to automatically enter the drive parameters. The operator can also manually enter the drive parameters if they are available.

- Exit and select “Advanced CMOS Setup”, then set the following:

```
Quick Boot = Enable
1st Boot Device = Floppy
2nd Boot Device = IDE0
3rd Boot Device = Disabled (or CD-ROM if installed)
PS/2 Mouse Support = Disable
Use the down arrow key to scroll past "BIOS Cacheable"
CC00, 16k Shadow = Disabled
D000, 16k Shadow = Disabled
```

- Exit and select “Advanced Chipset Setup”, then select the following:

```
IRQ 12/M Mouse Function = Disabled
```

- Select “PCI/Plug and Play Setup”, and set the following:

```
Plug and Play Aware O/S = No
IRQ 10 = "ISA/EISA"
IRQ 11 = "ISA/EISA"
```

- Exit and select “Write to CMOS and Exit”

The system will save the configuration and automatically reboot.

Note: If MS DOS is to be installed next, place DOS Disk1 in a: drive.

## Half-Length CPU (1) Award BIOS Setup

The following BIOS Setup is for the Award BIOS (2A5III9B)

- Load Setup defaults
- Enter “Standard CMOS Setup”
  - Check and/or set Time and Date
  - Check Drive C: = Auto; Mode = Auto
  - Check Drive D: = None (Note: if a second drive is used, then set Drive D: = Auto; Mode = Auto)
  - Check Drive A: = 1.44M, 3.5in.
  - Check Drive B: = None
  - Check Halt On = No Errors
- Enter “BIOS Features Setup”
  - Set Quick Power On Self Test = Enabled
  - Check Boot Sequence = A, C, SCSI
  - Set:
    - C8000 - CBFFF Shadow = Enabled
    - CC000 - CFFFF Shadow = Disable
    - D0000 - D3FFF Shadow = Disable
    - D4000 - D7FFF Shadow = Enabled
    - D8000 - DBFFF Shadow = Enabled
    - DC000 - DFFFF Shadow = Enabled
- Enter “Chipset Features Setup”
  - Set:
    - Auto Configuration = Disabled
    - ISA Bus Clock Frequency = PCICLK/3
- Enter “Power Management Setup”
  - Check:
    - IRQ10 (reserved) = Enabled
    - IRQ11 (reserved) = Enabled
  - Set IRQ12 (PS/2 Mouse) = Disabled
- “Integrated Peripherals”
  - Set PS/2 Mouse Function = Disabled

## AMI BIOS (c)1998 Setup (586 Systems)

Note: BIOS date is located at the top of the Main Utility page. For 586 systems with AMI BIOS (c)1998, perform the following for BIOS setup:

- Reboot the DACS and enter the BIOS setup routine.
- Select “Auto Configure with Optimal Settings”, and choose “Y” for loading high performance settings.
- Exit and select “Standard CMOS Setup”, then set the following:

Enter correct time and date

- Set the following drive parameters:

Primary Master = Auto

Repeat procedure for each HDD in the system or select “Not Installed” in the remaining HDD fields.

Note: If “Dynamic Drive Overlay Error” is displayed after completing the BIOS settings and starting DOS, return to the Primary Master Setting and press “Enter” to automatically enter the drive parameters. The operator can also manually enter the drive parameters if they are available.

- Exit and select “Advanced CMOS Setup”, then set the following:

1st Boot Device = Floppy

2nd Boot Device = IDE0

3rd Boot Device = Disabled (or CD-ROM if installed)

Quick Boot = Enable

PS/2 Mouse Support = Disable

Check the following settings:

CC00, 16k Shadow = Disabled

D000, 16k Shadow = Disabled

- Exit and select “Advanced Chipset Setup”, then select the following:

USB Function = Disabled

- Exit and Select Power Management Setup

Power Management/APM = Disabled

- Select “PCI/Plug and Play Setup”

- Scroll past IRQ3 at page bottom to view IRQ 10 & 11 and Exit

IRQ 10 = “ISA/EISA”

IRQ 11 = “ISA/EISA”

- Exit and select “Save Settings”

The system will save the configuration and automatically reboot.

Note: If MS DOS is to be installed next, place DOS Disk1 in a: drive.

## Micro-Star 6163 BXMaster BIOS Setup

1. Do not plug the IDE cable into the blue connectors, which are for the on-board Promise ATA66 connectors. ASTi does not use these connectors.
  2. A voltage display may come up on boot. This is normal.
  3. After boot, a message indicating that the Ultra66 BIOS is detecting drives, followed by a pause. Then, the message "Ultra66 BIOS is not installed" will be displayed. This is also normal.
- Load Setup default. Under each category, set the following:
  - Standard CMOS Setup
    - Primary Drive: Auto, LBA
    - Halt on: No Errors
  - CPU Plug & Play III
    - CPU Speed: 600MHz (100x6)
  - PNP/PCI Configuration
    - Resources Controlled by: Manual
    - IRQ3: PCI/ISA PNP
    - IRQ4: PCI/ISA PNP
    - IRQ10: Legacy ISA
    - Assign IRQ for USB: Disabled
  - Integrated Peripherals
    - Init Display First: AGP
  - Power Management
    - Power Management: Disable
    - Modem use IRQ3: NA
    - Reserve IRQ9: No
  - Save settings and exit.

## Advantech PCA-6178 BIOS Setup

- Load Setup default (Performance). Under each category, set the following:
- Standard CMOS Setup
  - Primary Drive: Auto
  - Halt on: No Errors
- BIOS Features Setup
  - Boot Sequence: A, C, SCSI
- PNP/PCI Config
  - Resources controlled by: Manual or Displayed below
  - IRQ10: Legacy ISA
  - Assign IRQ for USB: Disabled
- Integrated Peripherals
  - Onboard PCI SCSI Chip: Disabled
  - Onboard SCSI Terminator: Disabled
  - USB Keyboard Support: Disabled
- Power Management
  - ACPI: Disabled

Save settings and exit.

## MiniDACs: JUKI-3711PT BIOS Settings

This document provides BIOS settings for the JUKI-3711PT for use as an ASTi system. After completion, please refer to the ASTi Cold Start Procedure for instructions on installing OS and other ASTi related software.

The settings and steps are listed below:

1. Press DEL on power up to enter Setup.
2. Load Setup default -- no need to reboot.
3. Under each category, set the following settings:

Note: All systems may not have all menus.

- Standard CMOS Setup
    - Halt on: No Errors
  - Advanced BIOS Features
    - First Boot Device: Floppy
    - Second Boot Device: HDD-0
  - Power Management
    - ACPI: Disabled
  - PNP/PCI Config
    - Resources Controlled By: Manual
  - IRQ Resources
    - IRQ10: Legacy ISA
4. Save and Exit Setup

## MiniDACs: JUKI-3711PTN BIOS Settings

This document provides BIOS settings for the JUKI-3711PTN for use as an ASTi system. After completion, please refer to the ASTi Cold Start Procedure for instructions on installing OS and other ASTi related software.

The settings and steps are listed below:

1. Press DEL on power up to enter Setup.
2. Load Fail-Safe Defaults -- no need to reboot.
3. Under each category, set the following settings:

Note: All systems may not have all menus.

- Standard CMOS Setup
    - Halt on: No Errors
    - A Drive: 1.44 MB
  - Advanced BIOS Features
    - Virus Warning: Disabled
    - First Boot Device: Floppy
    - Second Boot Device: HDD-0
  - Power Management
    - ACPI: Disabled
  - PNP/PCI Config
    - Resources Controlled By: Manual
  - IRQ Resources
    - IRQ10: Legacy ISA
4. Save and Exit Setup