



Advanced Simulation Technology inc.
500 A Huntmar Park Drive
Herndon, Virginia 20170 U.S.A.
Tel. (703)471-2104 • Fax. (703)471-2108
www.asti-usa.com

ASTi

Touchscreen Display

Quick Start Guide

Document: DOC-01-TSD-QSG-1

Product Name: Touchscreen Display

ASTi Touchscreen Display - Quick Start Guide

© Copyright ASTi 1999-2006.

Restricted Rights: Use, duplication, or disclosure by the Government is subject to restrictions as set forth in subparagraph (c)(1)(ii) of the Rights in Technical Data and Computer Software clause at DFARS 252.227-7013.

This material may be reproduced by or for the U.S. Government pursuant to the copyright license under the clause at DFARS 252.227-7013 (1994).

ASTi

500 A Huntmar Park Drive

Herndon, VA 20170

Table of Contents

1.0 Touchscreen Description	1
1.1. Technical Specifications	1
1.1.1. Physical Specifications	3
1.1.2. Memory	3
1.1.3. Real-Time Clock	3
1.1.4. Ethernet Output	3
1.1.5. Keyboard Output	3
<i>Figure 1: Female Mini-DIN Connector</i>	3
1.1.6. Power Source	4
1.1.7. Speaker	4
<i>Figure 2: Touchscreen Backview (G70)</i>	4
<i>Figure 3: Touchscreen Backview (G75)</i>	5
1.1.8. Serial Ports	6
<i>Figure 4: Female DB9 Connector (back of unit)</i>	6
2.0. Getting Started	7
<i>Figure 5: Touchscreen Startup Screen</i>	7
2.1. Power On Setup	8
<i>Figure 6: Power On Setup</i>	8
2.1.1. Steps to Setup Your Touchscreen.	9
2.1.2. Touch Key Descriptions for Power On Setup	9
2.1.3. Power On Setup Functions	10
2.2. Touchscreen Calibration	14
3.0. Downloading A Model.	15
<i>Figure 7: Qlarity Download Icon</i>	15
<i>Figure 8: Model Selection</i>	15
Reference	17

1.0 Touchscreen Description

The touchscreen is a graphic terminal with object-based programming and Ethernet connection. The analog-resistive touchscreen covers the full viewable area of the display including the pre-labeled legend underlay on each side of the display.

Before purchasing the touchscreen, the user has the option to contract with ASTi to build a model or to simply build their own model. The purpose of the touchscreen model is to provide an interactive operator interface compatible with ASTi products including, Telestra, MBV, and DACS. For those interested in attaining the QSI tools to build a model refer to the QSI web site (<http://www.qsicorp.com/product/qlarity/>).

1.1. Technical Specifications

The tables below display the touchscreens' technical specifications. Please note there are two different touchscreen versions, the G70 (smaller size) and the G75 (larger size). For more information on size differences see section 1.1.1. Physical Specifications.

Touchscreen Display	
Color (standard)	STN 256 colors
Grayscale (optional)	FSTN 16 shades of gray
Active Matrix (optional)	TFT 256 colors
Enhanced TFT (optional)	Enhanced TFT 256 colors
Pixels	320 x 240 (G70) 640 x 480 (G75)
Dot Pitch	0.36 mm (G70) 0.33 mm (G75)
Contrast	Software-controlled, temperature compensated (N/A on TFT units)
Lighting	Cold-cathode fluorescent, brightness is software-controllable

Touchscreen
Analog-resistive operation
Transparent touch area over viewable display
Labeled touch underlay area on each side of display

Interface	
Standard	EIA-232 serial port with hardware or software handshaking
Baud rates	600-115,200 bps
Flow Control	None XonXoff (software) RTS/CTS (hardware)
Data formats	7 or 8 data bits 1 or 2 stop bits Even, odd, or no parity (PC Tools support only 8 data bits)
Connectors	DB9f 8-pin modular (RJ45) with Ethernet option PS/2 keyboard connector
Options	Primary serial port configurable as EIA-232, EIA-422, or EIA-485

Software	
Programming Language	Qlarity™ (object based)
Design Environment	Qlarity Foundry™ (Windows®)
Command Line Compiler	Qlarify (Win32® or Linux)

1.1.1. Physical Specifications

The touchscreen configuration is panel-mounted, housing a glass-filled polyester, UL 94V-0 flame rating, and accommodates panels from 0 to 7 mm thick with standard screws. The processor is a 200 MHz Intel® XScale™ core platform.

Physical Specification	G70	G75
Dimensions	215 x 161 x 50 mm	330 x 260 x 55.3 mm
Weight	1.16 kg.	2.9 kg
Temp. Ranges	Operating: -10 to 60°C Storage: -20 to 70°C	Operating: -10 to 60°C Storage: -20 to 70°C
Cutout Dimensions for Mount Configuration*	Horizontal 199 mm Vertical 145 mm	Horizontal 291 mm Vertical 221 mm
*Six screws are supplied for touchscreen mounting.		

1.1.2. Memory

The touchscreen is equipped with four megabytes of flash memory and sixteen megabytes of RAM memory. The touchscreen stores the firmware and the user application in a compressed format in flash memory. These are transferred into RAM memory after powering on the touchscreen.

The flash file system is used to store data collected by the application. The data is saved to flash memory so that it is available even after the touchscreen is powered off and back on.

1.1.3. Real-Time Clock

The touchscreen is equipped with a real-time clock with a battery back-up. The real-time clock can be used to time/date stamp messages or for timed polling and program execution.

1.1.4. Ethernet Output

The Ethernet port has a standard 10/100Base-T interface with an 8-pin (RJ-45) modular jack connector using a TCP/IP protocol.

1.1.5. Keyboard Output

The PS/2 port provides the option to connect a standard PS/2 keyboard to the touchscreen. The keyboard may be used in addition to, or in place of, the touchscreen. Both the Power On Setup and the touchscreen setup utility recognize the touch keys and the keyboard.

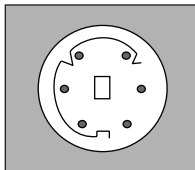

Figure 1: Female Mini-DIN Connector

1.1.6. Power Source

The touchscreen requires a DC power source in a range of 8 to 26 volts DC. This power is supplied via the main DB9 serial connector.

1.1.7. Speaker

The speaker provides audio to link to events or actions. Pitch and duration of a sound are controlled by API functions called from the user application.

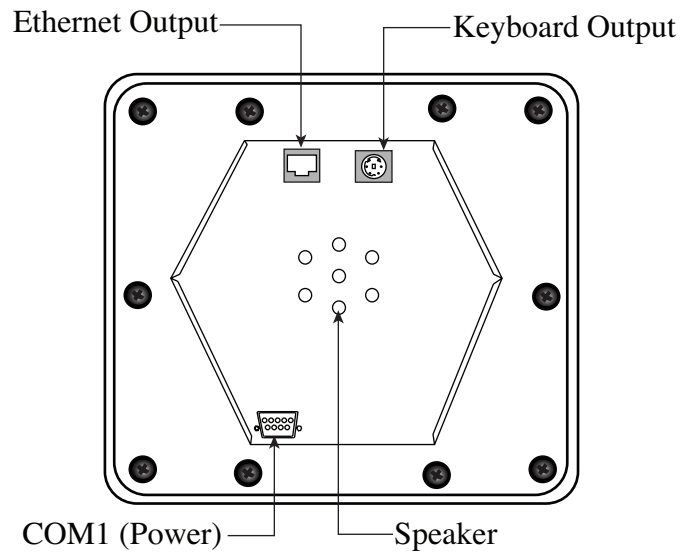

Figure 2: Touchscreen Backview (G70)

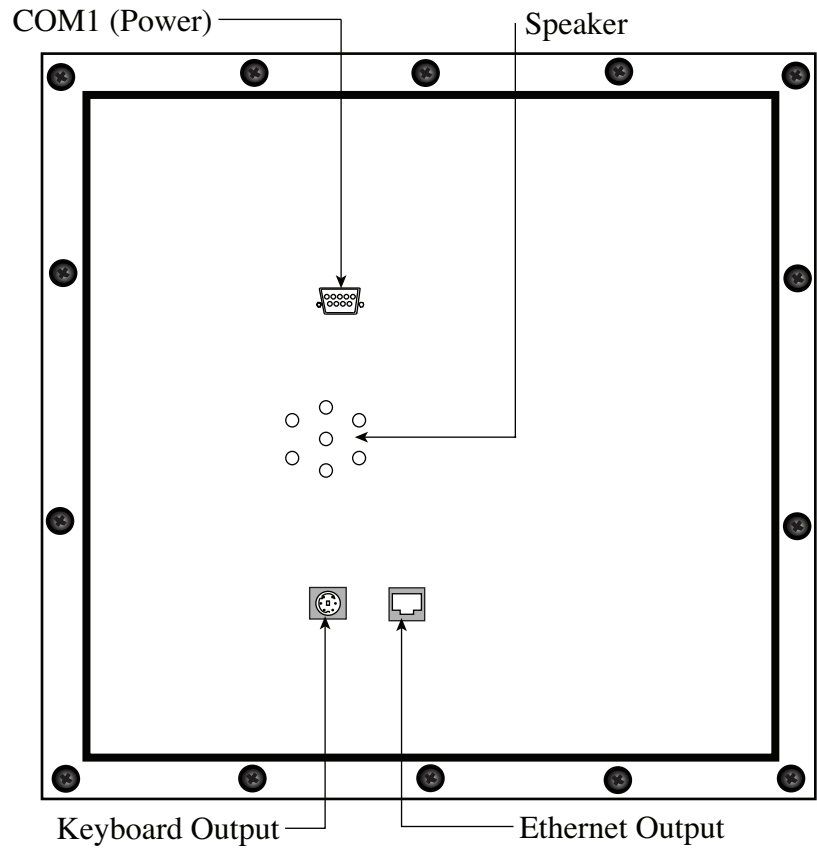

Figure 3: Touchscreen Backview (G75)

1.1.8. Serial Ports

The touchscreen comes with one serial port with DB9f connector. The serial port interface can be EIA-232, EIA-422, or EIA-485.

Cable	Description
EIA-232	With proper cables and grounding the touchscreen can communicate up to five meters at a top speed of 115,200 bps
EIA-422	Permits operation at distances up to 2,000 meters
EIA-485	Permits multiple touchscreens to be connected in a multi-drop chain

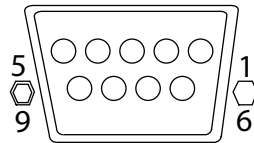

Figure 4: Female DB9 Connector (back of unit)

Power is supplied to the touchscreen through pin 9 and ground is supplied through pin 5 of the primary serial port connector.

2.0. Getting Started

If your touchscreen came with a model already loaded, it will automatically load the model application when powered on.

If your touchscreen was purchased without a model, the screen shown below will display upon startup. This will allow you verify that the touchscreen is operating properly.

Regardless of whether a model is loaded on your touchscreen or not, you can continue with section 2.0. to perform the 'Power On Setup.'

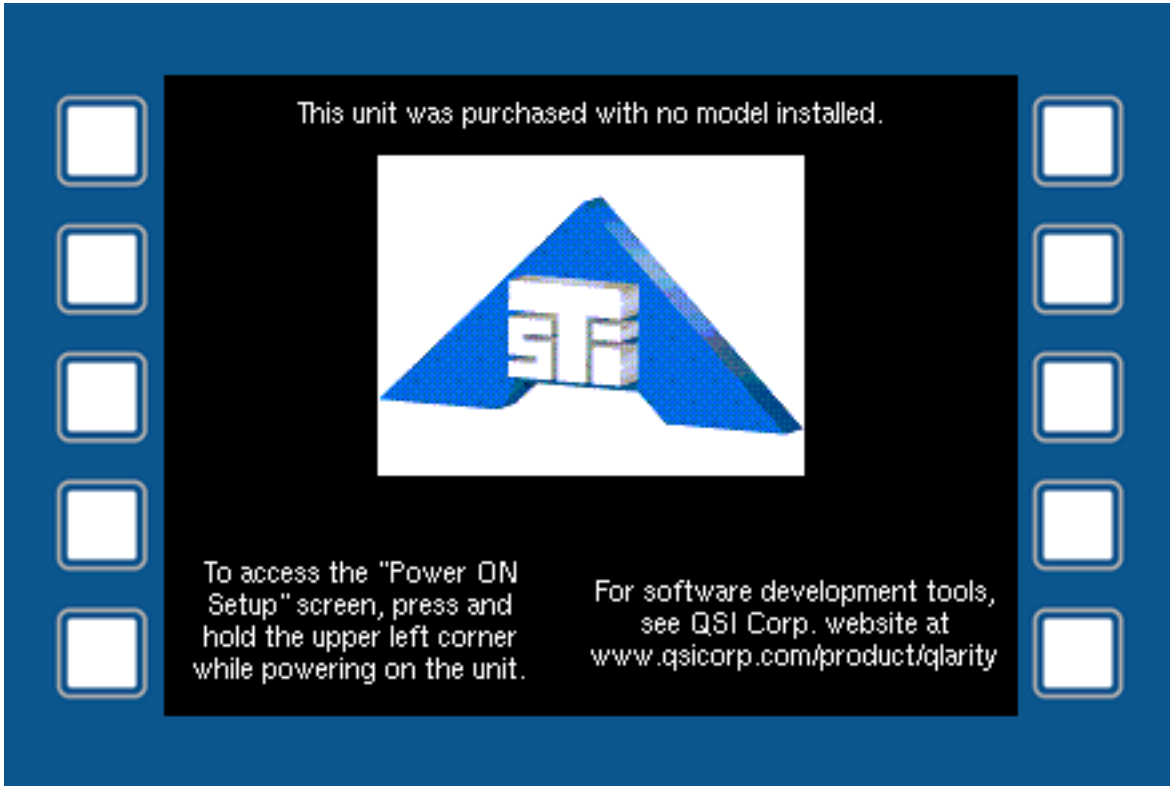

Figure 5: Touchscreen Startup Screen

2.1. Power On Setup

After powering on the touchscreen the user can set up or change the operation settings. The Power On Setup includes functions to do the following:

- Download new firmware and user applications
- Select the applications mode
- Set communications settings for the touchscreen
- Adjust display settings (contrast, backlight, orientation)
- Enter network (Ethernet) settings
- Perform touchscreen calibration
- Set the real time clock

The screen does not show the touch areas to enter the Power On Setup utility and calibration. These areas are shown the figure below. (After you enter the Power On Setup, the touch keys used to perform the functions are shown on the screen.)

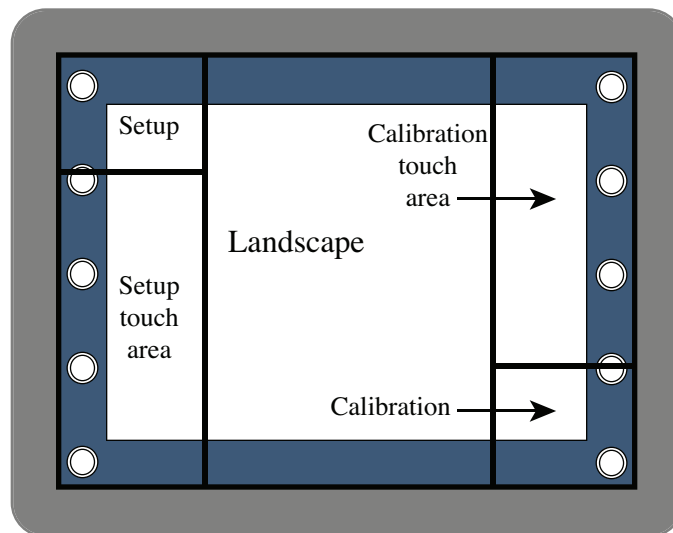

Figure 6: Power On Setup

Note: If your touchscreen is not working properly, it may need calibration, see section 2.2 Touchscreen Calibration for more information.

2.1.1. Steps to Setup Your Touchscreen.

1. Turn off power to the touchscreen.
2. Press and hold the **'Setup'** touch area as you power on the touchscreen.
3. Continue pressing until **'Power On Setup'** appears on the screen, then release the touch area.
4. If a password is required, the prompt, **'Enter password'** is displayed. Press the arrow touch keys on the screen to enter the password and then press **'Select.'** After you enter the password, the setup starts.

Note: If you enter the incorrect password, you will have to power off the touchscreen and start over. If a required password is not entered, or entered incorrectly, the Power On Setup starts with some limited functions including Display, Calibration, and Done.

2.1.2. Touch Key Descriptions for Power On Setup

Category to Category

- Press **'Next'** to move from one category to the next. The headings will highlight when you move to them. **'Next'** will also move you to the next page.
- Press **'Back'** to move backwards through the categories.

Within a Category

- Press **'Select'** to move to the first function you want to edit under the highlighted category.
- Press **'Next'** and **'Back'** to move from function to function in the category.
- Press **'Back'** in the top function of the category to go back to the category heading, or go to the bottom function and press **'Next.'**

Change a Function

- Press **'Select'** to edit the available options of a function when it is highlighted.
- Press **'Next'** or **'Back'** to navigate through the available options.
- Press **'Select'** to choose an option in the function.

Save and Exit

- Press **'Next'** or **'Back'** with a category heading highlighted to move to **'Done'** on the last page.
- Press **'Select'** to **'Save and Exit'** the setup or move to **'Exit w/o Save,'** if you don't want to save your changes.

2.1.3. Power On Setup Functions

This section describes the Power On Setup functions by category tables.

Flash Memory	
Description: The functions in this category are used to place the touchscreen in the correct mode to download new firmware, user application, or for developing a new application. The user can erase the flash file system in this mode.	
App Mode	Select this option to place a touchscreen with either a serial port or Ethernet port in the mode to download new firmware or a new user application that you want saved in the flash memory. Note: Use ' App Mode: Develop ' if you do not want to save the application in flash memory.
Develop	Select this option to set the touchscreen to the ' Develop ' application mode. Use 'Develop' when creating a new application and you want to download it to the touchscreen without saving it to flash memory.
Run App	Select this option to run in ' Run App ' operation mode. When you have a previously saved application in the flash memory and you are in Run App mode, the application will automatically run when the touchscreen is powered on.
Run Default	When in ' Run Default ' mode the default application associated with the firmware runs when the touchscreen is powered on. Note: Not all firmware builds have a default application.
Erase FFS	This function erases the flash file system.

Display	
Description: The functions in this category are used to change the display options.	
Contrast	Select this function to adjust to the desired touchscreen display contrast.
Backlight	Select this function to adjust the brightness of the display.
Orient	Select this function to adjust the orientation of the touchscreen display between vertical (portrait) or horizontal (landscape).
DCache	Draw caching (DCache) stores objects in memory to improve display performance but does not require more RAM to function. This improves latency when working in applications with many layered objects.

Calibration	
Description: The functions in this category are used to calibrate the touchscreen to the air temperature and the touchscreen if it is not working properly.	
Temp	If there is more than a 5°C difference between the shown default temperature set at the factory and the current air temperature, you may want to change this setting to help with display contrast.
Date	This function is used to set or change the real-time clock's date.
Time	This function is used to set or change the real-time clock's time.
Touchscreen	This function is used to calibrate your touchscreen if it is not working properly.

Network	
Description: This function is used to enter your network addresses for your Ethernet port.	

COM1 Serial Port	
Description: The functions in this category are used to configure your serial communications port.	
Baud Rate	Select the baud rate (600-115,200 bps).
Data Bits	Select the number of data bits, 7 or 8. The serial port must be set to 8 data bits to support user application downloads or firmware upgrades.
Parity	Select the parity setting, N (none), O (odd), E (even).
Stop bits	Select the number of stop bits, 1 or 2.
Flow Ctrl	Select the type of flow control, None, SW (XonXoff, software), or RTS/CTS (hardware).
Tx Timeout	Maximum time to wait to send data, if flow control is being used, before a transmission error occurs. This setting prevents the unit from hanging indefinitely while waiting to transmit if communication between the unit and its counterpart breaks down. The timeout is specified in the number of 20 ms ticks to wait.

Sound	
Description: This category will only appear if the audio decoder option has been installed.	
Volume	Set the master volume of the speaker.
Note Amplitude	Set the volume of beeps played by calls to PlayNote on units that include the optional audio decoder.

Feedback	
Description: The functions in this category control how the unit reports development information and fatal errors.	
Type	This function selects the method of feedback that the unit uses to report development information and fatal errors. The user can select any combination of COM1, Display, and UDP.
UDP	This function is used to set the IP address to send UDP packets to for feedback.
Port Number	This function is used to set the port number to send UDP feedback packets to.

Miscellaneous	
Description: The functions in this category include setting a password for Power On Setup and a unit information display screen.	
Information	Use this to determine the current version of firmware, current BFF version, minimum BFF version, amount of RAM, amount of flash memory, the current flash file system size, and ethernet MAC address of unit.
Use Password	This function determines whether or not a password is required to access the Power On Setup.
Change Password	This will appear if you selected 'Yes' for the 'Use Password' field. You can set up or change your Power On Setup password.

Keyboard	
Description: This category will only appear if a keyboard is connected to the touchscreen. The keyboard functions are used to set the key repeat delay time and rate.	
Rpt Delay	This function selects the delay time that you want between when a key is pressed and when it begins to repeat automatically.
Rpt Rate	This function selects the time that you want between each repeat when a key begins to repeat automatically.

Diagnostics	
Description: This category will display if you have a keyboard connected to your touchscreen. These functions are used to verify the keyboard keys are working properly.	
Keybrd Key	Use this function to verify that the keyboard keys are mapped correctly on the touchscreen.
Transmit Key	Use this function to send the results of the “Keyboard Key” test through the COM1 port.
SDRAM Test	The Qlarity-based touchscreens include the ability to do a comprehensive, non-destructive test on the synchronous DRAM memory. The contents of memory and the processor state are unharmed by the test.

Done	
Description: The functions in this category exit the Power On Setup with or without saving your changes.	
Save and Exit	All changes that were made while in the Power On Setup are saved and reflected the next time the touchscreen is powered on.
Exit w/o Save	If you select to exit without saving, the changes will not reflect the next time the touchscreen is powered on.

2.2. Touchscreen Calibration

If the touch keys are not working properly on the touchscreen, it probably needs calibration. If you cannot use the touch keys to navigate in the Power On Setup, do the following to switch the touchscreen to calibration mode:

1. Turn off the power to the touchscreen.
2. Press and hold the 'Calibrate' touch area (see Power On Setup figure in section 2.1. Power On Setup) as you power on the touchscreen.
3. Continue pressing until the message, "**TOUCHSCREEN CALIBRATION, Please press center of cross**" is displayed and a "+" symbol appears on the screen.
4. Press the "+" symbol, and the symbol moves to the bottom of the display.
5. Then press the "+" symbol in the new location.

The touchscreen calibration is complete.

3.0. Downloading A Model

After completing your touchscreen setup you are ready to download a model. The touchscreen comes with the Qlarity Download Utility which is used to download models.

1. Open the Qlarity Download Utility by double-clicking the icon.



Figure 7: Qlarity Download Icon

2. Select “**Browse**” to find the model file on your computer. The model file you select should be in a .bff format.
3. Next select to set up your touchscreen through the serial port option or Ethernet port option. Note that most users will connect the touchscreen via the Ethernet connection.
4. If connecting via the Ethernet port enter the touchscreen IP address. If connecting via the serial port enter the port options.
5. Verify your settings and select the “**Download Application**” button.

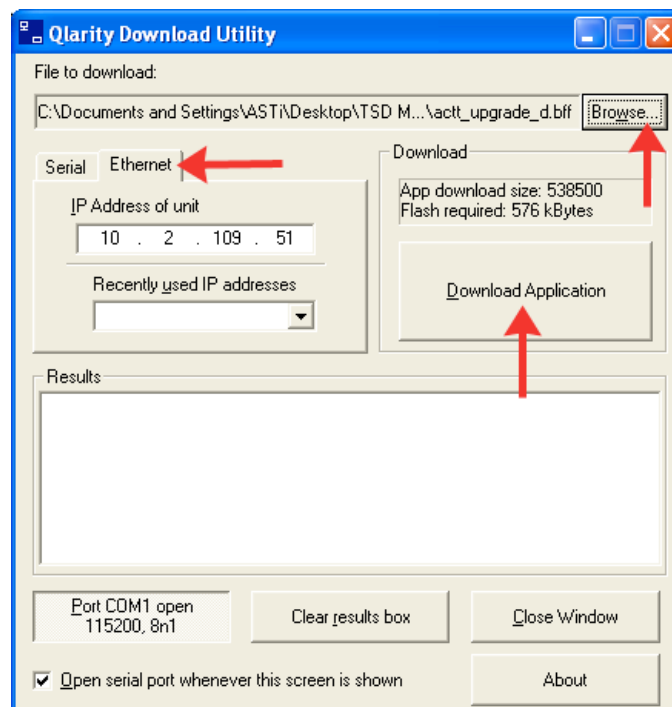
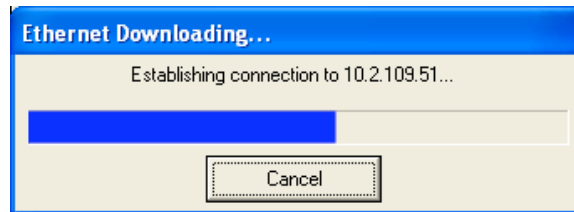

Figure 8: Model Selection

- The “Ethernet Downloading” screen will automatically display the status as the model downloads. Note that depending on model size this should only take a few seconds.



In order to verify that the model was properly loaded, simply wait until the model is visible on the touchscreen. If the touchscreen requires any further settings to be programmed (i.e. IP address, custom labeling, etc.), they will be explicitly detailed by the model creator in document format.

Reference

QSI Corporation. “QTERM-G70, QTERM-G75, and Power On Setup.” Qlarity-Based Terminal Hardware User’s Manual Rev. 2.40. 2006. 1-17, 35-47.